



1: SPORTING REGULATIONS - GENERAL

1.1: TITLE & JURISDICTION:

The **CLIO SPORT CHAMPIONSHIP** is organised and administered by the 750 Motor Club Ltd in accordance with the General Regulations of Motorsport UK (incorporating the provisions of the International Sporting Code of the FIA) and these Championship Regulations.

1. **MOTORSPORT UK Championship Permit No:** CH2024/R033
2. **MOTORSPORT UK Championship Grade:** C.
3. **Race Status:** Inter-Club.

1.2: OFFICIALS:

1. **Co-Ordinator:** G.Groombridge, 750MC, Donington Park, Castle Donington, Derbyshire, DE74 2BN

☎ 01332 814548; ✉ giles@750mc.co.uk.

2. **Eligibility Scrutineer:** B. Blackmore, [Deputy: S. Dockray](#)

3. **Championship Stewards:**

C. Chapman C. Emmerson I.Sowman

4. **Technical Advisor:** ~~S. Corner~~ [Adam Dorward](#) (K-Tec Racing)

1.3: COMPETITOR ELIGIBILITY:

1. Entrants must:
 - (a) be fully paid up valid members of the 750 Motor Club and
 - (b) be Registered for the Championship and
 - (c) be in possession of a valid MOTORSPORT UK Entrants Licences.
2. Drivers and Entrant/Drivers must:
 - (a) Be current Members of the 750 Motor Club and
 - (b) be Registered for the Championship and
 - (c) be in possession of valid Competition (Racing) Club Licence, as a minimum
 - (d) Or be in possession of the highest grade of national Race licence or valid FIA International Licence, together with their ASN's written consent ((H)26.2. and FIA ISC Article 2.3.7.b applies)
 - (e) If participation in the Championship requires absence from education a driver, in full time school education is required to have the approval of their head teacher and a letter stating such approval from their school in order to fulfil registration for the Championship. A driver shall not take time out of their education to participate in motor sport without the prior written approval of their education establishment.
3. All necessary documentation must be presented for checking at all rounds when signing-on.

1.4: REGISTRATION:

1. All competitors must register for the championship by returning the Registration Form with the Registration Fee to the Coordinator prior to the Final Closing date for the first round being entered.
2. The Registration Fee for the season is **£140** payable upon registration. For competitors wishing to enter a single event a registration fee of **£30** is payable and points will be awarded for this event. If further races are entered the balance of the **£140** fee must be paid..
3. Registration numbers will be the permanent Competition number for the Championship.

1.5: CHAMPIONSHIP ROUNDS:

The **Clio Sport CHAMPIONSHIP** will be contested over the following rounds:

Date	Circuit	Round/s
27/28 April	Brands Hatch	2
27 May	Castle Combe	2
6/7 July	Anglesey	3
3/4 August	Snetterton 300	3
21 September	Oulton Park	2
27 October	Silverstone	2

1.6: SCORING:

1. Points will be awarded to Competitors listed in the Final Results in each class as follows:-25; 22; 20; 18; 16; 14; 12; 11; 10; 9; 8; 7; 6; 5; 4; 3. All other finishers-2; all other starters - 1. Fastest lap per class - 1 point subject to a minimum of 2 starters in class. If there is only one starter in a class, there will be no point awarded for fastest lap.
2. The totals from all qualifying rounds run (excluding any races which are abandoned and which are not replaced) less 2 will determine the final championship points positions.
3. Ties shall be resolved using the formula in (W)1.3.4. in the current MOTORSPORT UK Yearbook.
4. Where the race distance has been reduced (2.6.) it shall still count as a full points scoring round.
5. Competitors not registered for the Championship may be permitted on an individual round basis and will:
 - (a) be deemed "Guest Competitors"
 - (b) not score points and for the purpose of points scoring will be ignored
 - (c) qualify for Event awards
 - (d) comply with the eligibility criteria as prescribed in Article 1.3. above, with the exception of 1.3.1. (b) and 1.3.2. (b), as appropriate

1.7: AWARDS:

1. All awards are to be provided by the Organising Club unless agreed otherwise.
2. Per Round: Trophies to 1st, 2nd and 3rd in each class and Driver of the Meeting as selected by a person or person appointed by the Championship Co-Ordinator.
3. Championship: Trophies, subject to a minimum of 5 race starts, to:-
1st, 2nd, 3rd, 4th, 5th & 6th overall and 1st, 2nd, 3rd in each class.
Best Prepared car.
4. Presentations: Awards will be presented at the end of each event, and/or at the end of the Championship at the designated presentation ceremony.
5. Entertainment Tax Liability: {deleted}
6. If Provisional Results or Championship Tables are revised after any presentations and these revisions affect the distribution of awards the Competitors concerned must return them to the organisers in good condition within 7 days.

2: CHAMPIONSHIP EVENT MEETINGS & RACE PROCEDURES

1. ENTRIES:

1. Competitors are responsible for sending in correct and complete entries with the correct entry fee prior to the closing date for entries before each event.
2. Incorrect or incomplete entries (Including Driver to be Nominated Entries) are to be held in abeyance until they are complete and correct and the date of receipt for acceptance of entry purposes shall be the date on which the Meeting Organiser receives the missing or corrected information or fee.
3. Any withdrawal of Entry or Driver/Car changes made after acceptance of any entry must be notified to the Meeting Organisers in writing. D25.1.12. applies.
4. The Entry Fee for each event shall be specified in the SRs and on the entry form.
5. Reserves will be listed in the Final List of Entries published with Final Instructions or in a Bulletin.

2. **BRIEFINGS:** Organisers should notify Competitors of the times and locations for all briefings in the Final Instructions for the meetings. Competitors must attend all briefings.

3. QUALIFICATION PRACTICE:

1. Should any Practice session be disrupted the Clerk of the Course shall not be obliged to resume or re-run the session; the decision of the Clerk of the Course shall be final.



2. Each driver shall complete a minimum of 3 laps in the car to be raced, and in the correct session, in order to qualify (MOTORSPORT UK Regulations Q12.4).

4. RACES: Should any race be disrupted the Clerk of the Course shall not be obliged to resume or rerun the race ((Q)12.15) (1.6.4. above applies)

5. STARTS:

1. All cars will be released to form up on the grid prior to the start in formation as specified on the grid sheet.
2. The start will be via Standing start. The minimum Countdown procedures/audible warnings sequence shall be:-
 - I. 1 minute to start of Green Flag/Pace Lap - Start Engines/Clear Grid.
 - II. 30 Seconds - Visible and audible warning for start of Green Flag/Pace Lap.
 - III. A five second board will be used to indicate that the grid is complete.
 - IV. The red lights will be switched on five seconds after the board is withdrawn.
3. Any car removed from the grid after the 1 minute stage or driven into the pits on the Green Flag lap shall be held in the pitlane and may start the race after the last car has passed the startline or pitlane exit, whichever is the later to take the start from the grid.
4. Any driver unable to start the Green Flag/Pace lap or start are required to indicate their situation as per MOTORSPORT UK Regulation (Q)12.11.2. In addition any driver unable to maintain grid positions on the Green Flag Lap, to the extent that ALL other cars are ahead of them, may complete the Green Flag lap but MUST remain at the rear of the last row of the grid but ahead of any cars to be started with a time delay.
5. In the event of any starting lights failure the Starter will revert to use of the National Flag.

6. SESSION RED FLAG: Should the need arise to stop any race or practice; RED LIGHTS will be switched on at the Startline and RED FLAGS will be displayed at the Startline and at all Marshals Signalling Points around the Circuit. This is the signal for all drivers to cease circulating at racing speeds, to slow to a safe and reasonable pace and to return to the pit lane, during practice, and to the starting grid area, during a race, unless otherwise directed by officials. Cars may not enter the Pits unless directed to do so. Work on cars already in the Pits must cease when a race is stopped.

7. PITS, PADDOCK & PITLANE SAFETY:

1. Pits & Paddock: Competitors must ensure that MOTORSPORT UK, Circuit Management and Organising Club Safety Regulations are complied with at all times.
2. Pitlane: The outer lane or lanes are to be kept unobstructed to allow safe passage of cars at all times. The onus shall be on all Drivers to take all due care and respect the pit lane speed limits.
3. Refuelling: May only be carried out in accordance with the MOTORSPORT UK General Regulations, the Organising Club Regulations, Circuit Management Regulations and the SRs or Final Instructions issued for each Circuit/Meeting.
4. Speed Limit: Pit Lane Speed Limit will be 60 km/h.

8. RACE FINISHES: After taking the Chequered Flag drivers are required to:

- I. progressively and safely slow down
- II. remain behind any competitors ahead of them,
- III. return to the Pit Lane Entrance/Paddock Entrance as instructed,
- IV. comply with any directions given by Marshals or Officials
- V. keep their helmets on and harnesses done up while on the circuit or in the pitlane.

9. RESULTS: All Practice Timesheets, Grids, Race Results are to be

deemed Provisional until all vehicles are released by Scrutineers after Post Practice/Race Scrutineering and/or after completion of any Judicial or Technical Procedures. (MOTORSPORT UK regulation (D)26.3.)

10. TIMING MODULES: The 750 Motor Club utilises transponder-based timing and competitors must have a compatible transponder fitted and working and advise the race organisers of its number prior to the event. Compatible transponders include the AMB TRANX 260 and MyLaps X2 & TR2 models.

11. QUALIFICATION RACES: If any event is oversubscribed the Organising Club may at their discretion run Qualification Races.

12. OPERATION OF SAFETY CAR: The Safety Car will be brought into operation and run in accordance with Section Q, Appendix 3 of the MOTORSPORT UK General Regulations.

13. ONBOARD CAMERAS:

All competitors are required to carry an on board, in car camera that records to an SD (or micro-SD) card that must be capable of recording HD footage that can be played back on a standard laptop. Recordings from the cameras may be used where there is an incident which is subsequently brought before the Clerk of the Course for investigation.

It is the competitor's sole responsibility to ensure safe installation and effective operation of the camera equipment. At all times cameras must be fitted in accordance with MOTORSPORT UK regulations and be approved by the Chief Scrutineer in accordance with J.5.21. Cameras must be mounted in a position such that the steering wheel and track in clear view. The unit must always be switched on and be recording when the car is on track during any official free practice, qualification session and race.

The onus is on the competitor to ensure that the camera unit battery is charged, the camera switched on to record and ensure the SD card has enough capacity to record the above-mentioned sessions. The SD card must ONLY contain the files from the event in question

In the event that no recording is available when requested by the Organisers or Clerk of the Course for judicial purposes then the following penalties will be applied by the Clerk of the Course.

- a. First offence – Championship Reprimand
- b. Second Offence - Championship Points Deduction – Equivalent to an 8th place finish.
- c. Third Offence - Disqualification.

3: SPECIFIC CHAMPIONSHIP REGULATIONS

1. By registering for the Championship all competitors and their associates commit to positively promote and demonstrate the Motorsport UK's Respect Code which is appended to these regulations (Appendix 6.3).

Where any reports of disrespectful conduct are judged to be well founded the Championship organisers may issue warnings or require remedial actions and/or report the matter to the Championship Stewards who may impose appropriate penalties which can include loss of Championship points and/or race bans through to Championship Expulsion and referral to Motorsport UK.

It is imperative that we promote the safety and wellbeing of young people and adults at risk. In addition to this all participants must be aware of their behaviour and conduct at all times and abusive language and harmful behaviour will not be tolerated. Any such incidents must be reported to the Championship Coordinator and/or Safeguarding Officer who will also relay the report Motorsport UK. Details of the Motorsport UK Policies and Guidelines are available at



www.motorsportuk.org/resource-centre by selecting Policies and Guidelines.

2. In the event of any rounds being oversubscribed the Organising Club may, in liaison with the Championship Coordinator, at their discretion run Qualification races as per 2.11 of these regulations. Alternatively, at double header race meetings, should there be sufficient space within the timetable, the Organising Club may divide the grid after qualifying into 3 separate Groups. The Groups will then form 3 races whereby each competitor participates in two races. All 3 races will be eligible for full championship points.

At each Round of the championship Race 1 grid positions will be determined by each competitor's fastest lap time in Qualifying. At double header meetings, the grid positions for Race 2 will be determined by the competitors fastest lap in Race 1. At triple header race meetings, the grid will be determined by the competitors fastest lap in Race 2.

3. The Championship co-ordinator reserves the right to request the fitting of a 750MC owned data logging system to any car prior to competition. Failure to comply will result in disqualification.

4. The championship organizers reserves the right to request the fitting of 750MC owned dampers and lower arms or place a competitor's car on a mobile dynamometer whilst in parc fermé. Failure to comply will result in disqualification.

4: SPECIFIC CHAMPIONSHIP PENALTIES:

In accordance with Section C of the current MOTORSPORT UK Yearbook and additionally:

4.1: INFRINGEMENT OF TECHNICAL REGULATIONS:

1. Arising from post practice Scrutineering or Judicial Action:
Minimum Penalty: The provisions of MOTORSPORT UK Regulations: C3.3.
2. Arising from post-race Scrutineering or Judicial Action:
Minimum Penalty: The provisions of MOTORSPORT UK Regulations: C3.5.1 (a) and (b).
For infringements deemed to be of a more serious nature the Clerk of the Course will invoke the provisions of Regulation C3.5.1 (c).

4.2: ADDITIONAL SPECIFIC CHAMPIONSHIP PENALTIES

1. In the case of a driver being disqualified from a race, the Clerk of Course will impose the penalties set out in MOTORSPORT UK Regulation C3.5.1 a & b and may impose the penalty set out in MOTORSPORT UK Regulation C3.5.1 c.
 2. In order to maintain standards of conduct, the Championship Organisers will monitor all Officials/Observers reports of adverse behavior at race meetings. If any individual is included on two such reports during one racing season the Championship Organisers will request the Clerk of Course at future race meetings to consider specific observation of that driver's conduct.
 3. The Clerk of Course may impose a "Stop-Go" or "Drive through" penalty during a race in accordance with MOTORSPORT UK Regulation Q.12.26.
 4. Any Competitor who is penalized under the Championship Sporting Regulations at any stage of a Championship event and receives an allocation of penalty points on their race license in accordance with MOTORSPORT UK Regulations, will receive a Championship points deduction equal to the number of penalty points which were allocated. Should the same competitor receive penalty points at another round of the Championship then the number of Championship points deducted will be double the number of penalty points applied. If penalty points are applied at a third round, then the Championship points deducted will be triple this number, and quadrupled at the fourth occurrence of such a penalty etc. This may result in a driver receiving a negative score.
5. Championship Stewards are also empowered to consider any

request from the Championship co-ordinator to penalize any Competitor for any breach of Championship regulations and, after holding a formal hearing if they deem it necessary, to impose a penalty in accordance with MOTORSPORT UK Regulation C.2.1.1 (subject to the rights of appeal provided for in Section C.)

6. One or more of the following may be imposed by the Championship Stewards as appropriate;

- a) Reprimand
- b) Fine. This may be also applied in the case of a driver receiving three reprimands from the Championship Stewards in one season.
- c) Time or Grid Penalties
- d) Suspension from all or part of the Championship. This may also be applied in the case of a driver receiving two fines from the Championship Stewards in one season.

5: TECHNICAL REGULATIONS

5.1: INTRODUCTION:

a) The following Technical Regulations are set out in accordance with the MOTORSPORT UK specified format and it should be clearly understood that if the following texts do not clearly specify that you can do it, you must work on the principle that you cannot. The fact that some modifications are mentioned as prohibited does not imply that others are allowed.

b) **STANDARD:** The word 'standard' used within these technical regulations as a description of components is to be interpreted as per 'Standard Part' defined in Section B – Nomenclature & definitions in the MOTORSPORT UK Yearbook. Checking will be by comparison to spare parts supplied by the manufacturer's official agent or by any other means necessary to ensure compliance. It applies to the specified component/s from the manufacturer's parts list for the model / engine shown on the entry form or registration form. No modifications permitted beyond the repair or adjustment processes specifically specified by the manufacturers' workshop manual or microfiche.' Checking will be by comparison to spare parts supplied by the manufacturer's official agent or by any other means necessary to ensure compliance. Where specifications for parts (e.g camshaft, final drive, gear ratios, anti-roll bars etc) are stated within table 6.3 of these regulations, they are mandatory for that make and model of car.

c) **STANDARD PATTERN:** The words 'standard pattern' used within these technical regulations as a description of components is to be interpreted as per 'Standard Pattern Part' defined in Section B – Nomenclature & definitions in the MOTORSPORT UK Blue Book. Checking will be by comparison to spare parts supplied by the manufacturer's official agent or by any other means necessary to ensure compliance.

d) Homologation papers, including VO, VK or ES extensions, will not be accepted as proof of specification of any components.

5.2: GENERAL DESCRIPTION:

1) The **CLIO SPORT CHAMPIONSHIP** is for Competitors participating in the following models of car:

CLASS A: RENAULT 182 CLIO CUP Hatchback Car [Model: CLIO II, Model Type: CB22.] For validity and procurement of Standard parts [5.1.b and c] the Vehicle Identification Number is: VF1CB220F32892321

CLASS B: RENAULT CLIO 197 and 200 [Model: CLIO III, Model Type: CR1N] that have the larger diameter front suspension top mounts (part numbers 7701208822 (N/S) 7701208823 (O/S)) that were fitted on vehicles manufactured prior to mid-2010.

All vehicles must have been available on general catalogued sale and available from stock through normal retail dealer outlets in the UK being only RHD and as specified by the 750 Motor Club Limited.



The engine capacity is 2000cc multi-valve per cylinder. This capacity limit is the original engine size.

There are no restrictions on the trailering of cars to/from the circuit. All vehicles must be of sound construction and mechanical condition and be well maintained. There is no requirement for an MOT Certificate, Road Tax or Insurance. It is the intention of the 750 Motor Club Limited to equalise the performance of the cars by setting minimum weights. The 750 Motor Club reserves the right to amend the minimum weights specified in 5.14.1 at any stage of the season by giving 7 days' notice.

2) Examination of vehicles. The organisers (in addition to any other powers they may have under these regulations) reserve the right before or after any race in the series to designate any one or more of the competing cars for special eligibility scrutineering. Competitors must be prepared, with tools and spare parts as necessary, to enable inspection of components, or to have units sealed at the circuit for later inspection by an Eligibility Scrutineer at the Competitor's expense.

Upon such selection being made the competitor shall immediately place the car under the control of the organisers and be deemed to have permitted all such scrutineering, examination and testing as the organisers may reasonably require. The organisers have the right to:

- a) Examine the car at the circuit for such period as they may reasonably require and take fuel samples.
- b) Retain the car for detailed examination at premises chosen by the organisers. If the organisers elect to retain the car they shall make it available for collection by the competitor at least seven days prior to the qualification session for the next race in the series unless the car is found to be in breach of these regulations.
- c) Seal the car and its components in such a manner as they may choose and require the competitor at their own expense to present the car at any other premises chosen by the organisers for detailed examination within a specified period and / or remove the car by transporter at no expense to the competitor to an appointed location. The competitor will be advised in writing of the time, date and location of the subsequent testing or eligibility examination. The overseen stripping of the engine or any required component will be undertaken by the competitor and / or mechanic / technician nominated by the competitor.

5.3: SAFETY REQUIREMENTS:

The Articles of MOTORSPORT UK Section K Safety Criteria Regulations will apply, and specifically:

CLASS A: A Six-point bolt in roll cage to K Drawing No 5 ONLY. Roll cages must have a single door bar on both the driver and passenger side of car but double door bars to either K Drawing No. 12g or 12h are STRONGLY RECOMMENDED. For the avoidance of doubt Safety Devices cages with the serial number R022 and R022 5SXX are permitted, however those with the serial number R017 are not permitted. Custom Cages, cage number RC2B/017 is permitted. A Harness Bar (1.1.13) is compulsory and must be fitted as per 1.3.9 to supplement 'Hans' devices.

CLASS B: The only permitted roll cage is the KTR 3RS MOTORSPORT UK Six-point bolt in roll cage supplied by K-Tec Racing (part number: 010/KTR/ROL/066B). For cars built prior to 2021 the Safety Devices roll cage with the part number R019 is permitted.

CLASSES A & B: Seat belts as per K2.1 (not 2.1.2) and FIA homologated ; K2 and K5 - K14; Extinguishers must be plumbed in and comply with K 3.1.

5.4: GENERAL TECHNICAL REQUIREMENTS & EXCEPTIONS:

All cars must comply with the requirements of sections J and Q of the current MOTORSPORT UK Yearbook. All vehicles must be of sound construction and mechanical condition and be well maintained. Water hoses, oil hoses, power steering hoses and their

associated clips are free. Rose Joints of any type are prohibited [except as fitted to mandatory items]. AN ELIGIBILITY GUIDE [TECHNICAL SPECIFICATIONS] HAS BEEN PREPARED AND THE CAR MUST COMPLY WITH THOSE SPECIFICATIONS AS DETAILED IN SECTION 6.0

The organisers reserve the right to refuse entry from a any car of which the preparation is of a poor standard (including the external appearance) and which is likely to bring the championship into disrepute.

5.5: CHASSIS:

CLASS A & B: No chassis stiffening is permitted except that derived from the fitting of the roll cage using only the six mounting feet inside the car, no other attachment to the bodyshell is permitted even if provided by the cage manufacturer. Seam-welding of the shell is prohibited; fitting of a front or rear strut brace is prohibited. No modifications to body shell are permitted except the removal of redundant inertia trim/reel mounts.

5.6: BODYWORK:

CLASS A

1. Modifications Permitted:

1. **General:** Mandatory fitment of laminated windscreen.
2. **Interior:** Driver's seat may be replaced. Passenger seat, rear seats, floor coverings, roof lining, detachable boot covers (parcel shelf), radio/stereo units speakers and associated wiring, spare wheel and tools may be removed. Steering wheel may be changed (compulsory if an air bag is fitted as original equipment). Electric window winding mechanisms must be retained; all windows must remain operable and all weather strips/channels must be retained. It is permitted to remove the air-conditioning if fitted [subject to conditions stipulated in 6.1.4]. An interior rear-view mirror must be fitted to the left of the driver. Front door panels may be replaced with aluminium or carbon fibre sheeting or suitable plastic sheeting - this must be executed to a high standard with no sharp edges and with smooth surface. The central locking mechanisms including locking motors must be removed; manual interior door lock mechanisms must be disabled. The standard door latching mechanism must be retained.
3. **Exterior:** The standard Driver and passenger wing mirror 'pods' must be retained but the choice of mirror within them is free. Plastic front wheel-arch inner liners must be removed. Bonnet and rear hatch locks/latches must be removed along with any auxiliary latch; the bonnet and rear hatch must be fitted with securing pins. The original number of front windscreen wiper arms/blades must remain and be fully functioning. The tailgate wiper mechanism and arm/blade may be removed. Front and rear washer systems may be removed. Headlamp washers may be removed and holes covered. No other alterations to standard. All weather strips/channels must be retained.
4. **Silhouette:** No alterations to standard.
5. **Ground Clearance:** It is permitted to alter the ride height. Under no circumstance can any part of the bodywork, or of the suspended part of the car [excluding the exhaust system], be below a horizontal plane passing 75mm above the ground, the car being in normal racing trim with the driver aboard. A gauge of 75mm may be used by Scrutineers before or after races or practice to check the ground clearance; the vehicle may be stationary or moving during any testing.

CLASS B

1. Modifications Permitted:

1. **General:** Mandatory fitment of laminated windscreen.
2. **Interior:** Driver's seat may be replaced. Passenger seat, rear seats, floor coverings, roof lining, detachable boot covers (parcel shelf), radio/stereo units speakers and associated wiring, spare wheel and tools may be removed. Steering wheel may be changed (compulsory if an air bag is fitted as original equipment). Electric window winding mechanisms may be removed and front side windows replaced with Polycarbonate windows to J5.20.8; It is

permitted to remove the air-conditioning if fitted [subject to conditions stipulated in 6.2.4]. An interior rear-view mirror must be fitted to the left of the driver. Front door panels may be replaced with aluminium, carbon fibre or suitable plastic sheeting - this must be executed to a high standard with no sharp edges and with smooth surface. The central locking mechanisms including locking motors must be removed; manual interior door lock mechanisms must be disabled. The standard door latching mechanism must be retained.

3. Exterior: The standard driver and passenger wing mirror 'pods' must be retained but the choice of mirror within them is free. Plastic front wheel-arch inner liners must be removed. Bonnet and rear hatch locks/latches must be removed along with any auxiliary latch; the bonnet and rear hatch must be fitted with securing pins. The original number of front windscreen wiper arms/blades must remain and be fully functioning. The tailgate wiper mechanism and arm/blade may be removed. Front and rear washer systems may be removed. Headlamp washers may be removed and holes covered. No other alterations to standard. All weather strips/channels must be retained. Any bracketry for attaching the rear wheel arch liner including the metal tab that is welded to the shell at the back of the wheel arch may be removed in order to prevent potential contact with the tyre.

4. Silhouette: No alterations to standard.

5. Ground Clearance: It is permitted to alter the ride height. Under no circumstance can any part of the bodywork, or of the suspended part of the car [excluding the exhaust system], be below a horizontal plane passing 75mm above the ground, the car being in normal racing trim with the driver aboard. A gauge of 75mm may be used by Scrutineers before or after races or practice to check the ground clearance; the vehicle may be stationary or moving during any testing.

2. Modifications Prohibited:

CLASS A & B:

1. General: The exterior of the car must be standard for the model being raced. Any replacement body panels must be of original shape, material and thickness. The reduction in thickness of any metallic part of the car by acid-dipping, blasting or by any other means is prohibited.

2. Interior: Rear passenger side panels, Tailgate trim panel, Rear boot trim panel may be removed. Driver and passenger upper mirror and rear window trim panels may be removed. Any other modification in contravention of 5.6.1.2 is also prohibited. The dash fascia/instrument cluster must remain as originally fitted except for immediately localized trimming for the fitment of the rollcage. The Handbrake cover and Gearlever cover to dash may be removed. The standard heater must be retained and fully functional for the purpose of demisting the front windscreen.

3. Exterior: It is not permitted to increase the width of the wheel arch by the addition of material to, or the deformation of, the outside or inside of the wheel arch. Additional holes for cooling, brake ducting, air intakes etc may not be made in the bodywork. Bonnet / engine cover must remain in the normal position and, when closed, must not have any non-standard gaps at any of their edges. Standard fitment auxiliary lights must be removed, these can be replaced with Renault blanking plates [CLIO 182 Renault part number: 7701209099] or a mesh/grill which must not allow a 15mm diameter sphere to pass through. Fitment of tape etc to close body gaps (e.g. bonnet to wing) is prohibited. Recessed bonnet & rear hatch securing pins are prohibited.

4. Silhouette: Any in contravention of 5.6.1.4.

5. Ground Clearance: Any in contravention of 5.6.1.5.

5.7: ENGINE:

The only permitted engines are as follows:

CLASS A: the Renault Clio 182 type F4R 738. All engine parts must be standard for the VIN: VF1CB220F32892321.

CLASS B: the Renault Clio 197/200 type F4R 830.

1. Modifications Permitted:

Class A & B:

- 1.1 The replacement of valves, valve guides and valve seats with parts of standard pattern and material is permitted. For the avoidance of doubt single piece construction valves are not permitted.
- 1.2 The replacement of engine mountings, upper engine, upper gearbox and lower stabiliser link is permitted using ~~with~~ only the parts listed and supplied by K-Tec Racing as per 6.1.8 for Class A and 6.2.8 for Class B
- 1.3 Big end and mains bearings are free. The use of ARP con rod bolts is allowed, all other bolts and fixings must be original Renault items.

1.4 The standard Renault Crank Pulley maybe replaced with the KTR F4R | F4R-T Billet Crank Pulley With Keysteel Keyway, KTR Part No: P000870.

2. Modifications Prohibited:

Any other than those permitted in 5.7.1. The maximum permitted compression ratio is 11.0:1 in Class A and 11.5:1 in Class B.

The camshafts must remain entirely unmodified; it is not permitted to regrind or re-profile or grind from blanks. The standard cambelt cover/s must be retained.

3. Location: Position and mounting method must be standard for the model being raced with the exception of fitting the parts specified in 5.7.1.2. No additional engine/transmission support may be fitted.

4. Oil/Water cooling: The water radiators must remain standard in design and position with no additional air ducting. An oil cooler may be fitted within the overall periphery of the engine bay; no additional air ducts are permitted. Internal baffles may be fitted to the standard sump; the sump oil pick-up pipe may be modified.

5. Induction Systems: The complete standard induction system must be retained in its entirety from the cylinder head to and including the air box casing; it is not permitted to add any covering, whether heat-reflective/heat-resistant or not, to the inside or outside of any part of the induction system. Air filter elements must be present but may be replaced by non-standard filter elements inside the standard casing. No other modifications are permitted. The crankcase breather may vent direct to a catch tank [catch tank size subject to MOTORSPORT UK requirements] and any holes in the air filter housing associated with the breather system may be blanked off.

6. Exhaust systems:

CLASS A: The complete standard exhaust manifold must be retained in its entirety. The Twin tail pipe exhaust system must exit at the rear of the vehicle as standard for the Clio CB22 model type [see silhouette 5.6.1.4]. Exhaust systems may not pass through the driver/passenger compartment. The remainder of the exhaust system including silencer(s) is free but no part of the manifold, piping or silencer may have any covering or lagging, whether heat resistant, heat reflective or not. The vehicle must be fitted with a catalytic converter in the exhaust system, OEM catalytic converters may be replaced with aftermarket versions but they must be fully functional and remain in the standard location. All exhaust gasses must pass through the catalytic converter(s) and exit the vehicle via both of the tail pipes. For the avoidance of doubt systems where exhaust gasses do not pass through both tail pipes simultaneously or where one tail pipe is not connected to the rest of the system are prohibited. Emissions testing may be carried out to ensure that exhaust gasses are passing through both tail pipes simultaneously and in comparable amounts.





The standard heat deflector plates (or suitable replacements) fitted to the underside of the body must be retained for the full length of the exhaust system plus a suitable heat shield must be fitted between the manifold and lower bulkhead in order to protect key braking components.

CLASS B: The complete standard exhaust manifold must be retained in its entirety. The "pre-cats" may have their internals removed. The remainder of the exhaust system including silencer(s) and catalytic converter(s) may only be replaced with the parts listed in 6.2.5

CLASS A & B: All exhaust gasses must pass through the catalytic converter(s) and exit the vehicle via both of the tail pipes. For the avoidance of doubt systems where exhaust gasses do not pass through both tail pipes simultaneously or where one tail pipe is not connected to the rest of the system are prohibited. Emissions testing may be carried out to ensure that exhaust gasses are passing through both tail pipes simultaneously and in comparable amounts.

7. Ignition systems:

Class A: It is a mandatory requirement to *only fit and run the Clio series Engine Control Unit [ECU] Part Number KTRGEN90R750. The ECU is 182 specific supplied pre-mapped and locked with diagnosis and initial setup software and comms lead. The sole supplier is K-Tec Racing, for supplier details see 6.1.5.* The ECU is a sealed item and all seals must remain intact at all times. For ECU repairs or Servicing use only the Sole Supplier. The organisers can at any time before or after a race or practice replace the competitors ECU with their own sealed unit, swap competitors ECU's between cars. No alternative or additional ECU is permitted. Plug leads and Spark plugs are free. No additional sensors are permitted. Only the standard sensors as detailed in 6.5 are permitted. Sensors must be fitted in standard positions. The second oxygen exhaust sensor after the Catalytic converter can be removed as it is not used by the ECU. The air inlet 'cold start' flap housing must be removed for racing together with the associated air pipes to the air box casing, as the function is not used by the ECU.

Class B: It is a mandatory requirement to retain the standard Engine Control Unit [ECU] which must have a control map installed by K-Tec Racing. No alternative or additional ECU is permitted. Plug leads and Spark plugs are free. No additional sensors are permitted. Sensors must be fitted in standard positions.

8. Fuel delivery systems:

Class A: It is permissible to replace only the fuel lines, and filter with non-standard items. The engine fuel gallery shield block must be retained and fitted [part 8200110830]

Class B: The fuel delivery system must remain standard.

9. Additional Specific regulations for Class A only.

9.1 ESP at present must be disabled at all times.

9.2 Charcoal filter may be removed.

5.8: SUSPENSIONS:

(Refer to 5.1). The original suspension configuration must be retained. Standard Front anti-roll bars must be retained and be properly connected. Standard chassis bump-stops must be fitted in the standard position.

1. Permitted modifications: It is permitted to alter the ride height within the constraints of 5.6.1.

Class A: It is a mandatory requirement for all cars to run with the *K-Tec Racing Clio Series specification front and rear coil-over suspension kit Part Number KTRSX9005 and Front Top Mounts 050/KIT/KTR/002. For supplier details see 6.1.6.* All the items [and Bumpstops] supplied with the *K Tec suspension kit* must be utilised. Servicing and repairs to the mandatory dampers may only be carried out by Spax (see 6.1.12), re-valving and modifying the dampers is

prohibited. Only the adjustability of Front Tracking [toe in and toe out] and Front camber [see 6.1.3] within the limits of the mandatory suspension kit is permitted. The use of Rear Camber Shims is permitted however the Rear suspension geometry must remain within the limits specified in 6.1.3 at all times. All measurements will be checked with the driver in the driver's seat. The organisers can at any time before or after a race or practice replace the competitors Mandatory suspension items with their own sealed units and springs. Springs are fixed for length and rate. Bolts and fixings are free. The Renault M14 bolt (Renault Part No. 77 03 002 835) used to fix the front hub and suspension strut may be replaced with Powerflex Clio 2RS 14mm Camber Correcting Bolts.

5.8.1.1 A Renault recognised Modification to the front top chassis suspension mounting may of occurred [enlarging the shock-absorber mounting hole], and thus the mandatory Front Top Mounts may be difficult to fit. It is permitted to weld [fit] a top mount plate manufactured to the dimensions shown in 6.7.2, onto the top of the front top chassis suspension mounting in the position shown in 6.7.3.

Class B: It is a mandatory requirement for all cars to run with the K-Tec Racing Clio Series specification front and rear coil-over suspension kit (Part Number: 050/KIT/SPX/0014) and Front Top Mounts (Part Number: 050/KIT/KTR/0016.) All the items supplied with the K-Tec Racing suspension kit must be utilised. Servicing and repairs to the mandatory dampers may only be carried out by Spax (see 6.2.12), re-valving and modifying the dampers is prohibited. Only the adjustability of Front Tracking [toe in and toe out] and Front camber [see 6.2.3] within the limits of the mandatory suspension kit is permitted. The use of Rear Camber Shims is permitted however the Rear suspension geometry must remain within the limits specified in 6.2.3 at all times. All measurements will be checked with the driver in the driver's seat. The organisers can at any time before or after a race or practice replace the competitor's Mandatory suspension items with their own sealed units and springs. Springs are fixed for length and rate. Bolts and fixings are free but must retain OEM sizes and material. Suspension bushes may be replaced with uprated Powerflex bushes as specified in: 6.2.6, the axle may be strengthened using the parts listed in 6.2.13

2. Prohibited modifications:

Class A: Modifications to any of the suspension pick-up points are prohibited [except as in 5.8.1.1 above]; *this includes the 'slotting' of any suspension mounting points.* Lower arms must be as Renault supplied for the Clio CB22 model type with no modifications. The moving, enlarging or repositioning of any holes or adding spacers or washers is prohibited. Offset bolts are also prohibited. Cockpit adjustable anti-roll bars are prohibited. Offset and/or adjustable suspension strut mounts are prohibited. Adjustable hub-carrier brackets are prohibited, even if the adjustability is disabled. Rear anti-roll bar is prohibited, non-standard suspension bushes are prohibited; rose joints, rod ends or similar are prohibited. Any modification which prevents a wheel from reaching its fully drooped position is prohibited. Use of any 'packing' or 'plates' is also prohibited.

Class B: Modifications to any of the suspension pick up points are prohibited [except as in 5.8.1.1 above]; *this includes the 'slotting' of any suspension mounting points.* Lower arms must be as Renault supplied for the Clio CR1N model type with no modifications. The moving, enlarging or repositioning of any holes or adding spacers or washers is prohibited. Offset bolts are also prohibited. Cockpit adjustable anti roll bars are prohibited. Offset and/or adjustable suspension strut mounts are prohibited other than those supplied with the mandatory suspension kit. Adjustable hub-carrier brackets are prohibited, even if the adjustability is disabled. Rear anti-roll bar is prohibited, Any modification which prevents a wheel from reaching its fully drooped position is prohibited. Use of any 'packing' or 'plates' is also prohibited.

3. Wheelbase/track: The wheelbase and track must be standard as detailed in 6.1.3 for Class A & 6.2.3 for Class B



5.9: TRANSMISSIONS:

(Refer to 5.1).

Gear selection and clutch operation must be purely standard for the model being raced, and solely under direct control of the driver. No electrical connections may operate on any part of the clutch or gear controls or linkages. Note CB22 model does have a clutch switch, that is not used by the control ECU, this can be retained but must not have any other electrical or electronic device connected to it *weather by wires/wireless/magnetic means*.

1. Permitted modifications:

Class A: None. Standard gearbox and final drive/axle for the CB22 model type must be retained as detailed in 6.1.3. The Clutch cover and plate may be changed for items made from uprated materials but must be of a full circumference and retain the standard pattern. For the avoidance of doubt paddle type clutches are not permitted. A list of part numbers of suitably compliant clutches can be found in section 6.1.11.

Class B: Standard gearbox and final drive/axle for the CR1N model type must be retained as detailed in 6.3. The differential may be replaced with a Blackline ATB type differential supplied by K-Tec Racing (part number: 060/TRA/BLK/0001.)

The Clutch cover and plate may be changed for items made from uprated materials but must be of a full circumference and retain the standard pattern. For the avoidance of doubt paddle type clutches are not permitted.

2. Prohibited modifications: Any other than those permitted in 5.9.1.

3. Transmissions & Drive ratios: The use of any electronic traction control device is prohibited. Standard gearbox ratios and final drive ratios for the model type must be retained.

5.10: ELECTRICS

1. Exterior Lighting: Must be as per standard fitment and be fully operational. Head lights must be taped to MOTORSPORT UK regulations.

2. Rear Warning Light: An FIA or MOTORSPORT UK approved LED rear fog light is mandatory and must be fitted within 10cms of the centreline of the rear window and be located between the top edge of the tailgate and bottom edge of the tailgate glass. Integral rear fog lights must be rendered inoperative.

3. Batteries: No restrictions on type subject to MOTORSPORT UK regulations; location must be as standard for cars in Class A. A battery and electric starter motor must be fitted and be capable of repetitive starts. No external (slave) batteries may be used.

4. Generators: A fully working standard alternator/generator and standard pulley must be fitted and electrically connected so that the standard battery charging function is providing a charge to the onboard battery.

5. Wiring: The original standard wiring loom must be retained except as detailed in 5.6.1.2. Wiring can be added to meet 5.3, 5.4, 5.10.2 and to furnish Lap Timers, and extra gauges.

5.11: BRAKES

Class A: ABS

There are two options, Option 1 for ABS as Standard, Option 2 Non-ABS. The Choice is either all Option 1 **OR** all Option 2, no combination of both options is permitted.

OPTION 1: The Renault Clio 182 Cup [CB22] is fitted with ABS as standard, this must remain standard and fully functioning with all original wheel sensors, ECU, pump and brake piping configuration. No modifications to the standard factory fitted system are allowed except as detailed in 5.11.1 below.

OPTION 2: The original ABS pump can be removed [NOT the ABS ECU] and brake piping configuration can be re-configured, but must have as mandatory the Tilton screw type proportioning valve [brake bias valve] part number 90-2000 fitted between the master cylinder and all rear brake wheel cylinders. The Mandatory Brake Bias valve location is free. The wheel sensors, wiring and ABS ECU must be

retained and fully functioning as standard. Permitted modifications as 5.11.1 below.

Class B: ABS

The Renault Clio 197/200 [CR1N] is fitted with ABS as standard, this must remain standard and fully functioning with all original wheel sensors, ECU, pump and brake piping configuration. No modifications to the standard factory fitted system are allowed except as detailed in 5.11.1 below.

1. Permitted Modifications: Non-standard linings. Fitting of alternative brake piping/hosing. Discs may be replaced by standard-pattern 'non-genuine' parts. The braking system must remain fully operational in all aspects at all times.

2. Prohibited Modifications: Discs / drums may not be cross-drilled or grooved. Any hydraulically-operated handbrake is not permitted.

5.12: WHEELS / STEERING

1. Wheels :

Class A: It is a mandatory requirement to only use either the 'Pro Race 1.2' wheels supplied manufactured by Rimstock Plc as per 6.1.9 or the Speedline Ruota wheels supplied by K-Tec Racing as per 6.1.9. Colour is free

Class B: It is permitted to replace the standard Renault wheels with Speedline SL1977 wheels supplied by K-Tec Racing. Colour is free.

STEERING LOCK: It is recommended that the steering lock should be rendered inoperative, unless the vehicle is driven to the circuit on the highway.

2. Prohibited Options. None of the VO, VK or ES extensions in the vehicle's homologation papers is permitted.

3. Construction & Materials: Not applicable; wheels must be as 5.12.1.

4. Dimensions: see 5.12.1

5. Steering Rack: The standard steering rack and hydraulic power steering must be retained as per the model being raced.

6. Wheel Studs & Nuts: Aftermarket wheel studs and nuts are permitted in both class A & B.

5.13: TYRES

1. Specifications: Tyres must retain a minimum tread depth of 1.2mm at all times. The use of tyre heating/heat retention devices, tyre treatments and compounds is prohibited. No alteration to the tyre from the manufacturer's specification is permitted. Re-cutting, re-grooving or in any other way modifying the tread pattern is not permitted. All the manufacturer's data must be clearly visible. Buffing of sidewalls to remove data is prohibited.

2. Nominated Manufacturers:

Class A: It is a mandatory requirement to only use the Toyo R888R – 195/50/15 (GG Compound.)

Class B: It is a mandatory requirement to only use the R888R – 215/45/R17 (GG Compound.)

3. Nominated supplier: The only permitted tyre supplier is Polleysport [see 6.5.6]. All tyres supplied by Polleysport will be barcoded (see example below.) Drivers will only be permitted to use a total of 18 tyres during the course of the season. At each event drivers are allowed to use a maximum of 8 tyres per race weekend. Drivers must nominate which tyres they are using at each race weekend, this will be done via a tyre information form listing the barcode identification numbers of the driver's chosen tyres. The completed tyre information form must be in possession of the scrutineers prior to the start of competition (for the avoidance of doubt this is the allotted Clio Sport practice session.) Any competitor found during post qualifying/race scrutineering, to have qualified or raced with a tyre not listed on the 'Tyre Information Form' will be disqualified from the results. Any competitor found to have not declared their chosen tyres prior to the practice session will be disqualified from the results and start from the back of the grid, but ahead of any cars incurring a delayed start due to time penalties. Tyres are not transferable between drivers. Any barcodes that are illegible or damaged beyond recognition must be requested to be replaced by Polleysport. The onus is on the competitor to ensure

this happens before entering a competitive session or practice or race.



5.14: VEHICLE WEIGHT:

1. **Class A:** A minimum weight including driver is set at -1060kgs.
Class B: A minimum weight including driver is set at 1215kgs. All minimum weights are including driver and race overalls, helmet etc. Random checks will be carried out during the season and no car/driver combination shall be below this minimum weight. If any vehicle is underweight penalties as per 4.1 of these regulations will be applied. Ballast can be added by competitors to achieve the minimum weight in 5.14.1 and should be carried in the car as per 5.14.2.
2. Ballast must only be mounted inside the car on the front passenger floor area. It is the responsibility of the competitor to provide and fit their own ballast as per the drawing in the Appendix 6.2 and to mount it to the satisfaction of the scrutineers. Care should be taken in the mounting, by use of suitable 'spreader plates' and appropriate size and quality of bolts with reference to MOTORSPORT UK regulation J5.15.
3. In order to achieve parity between the classes, the 750 Motor Club reserves the right to amend the minimum weights specified in 5.14.1 at any stage of the season by giving 7 days' notice in writing to all registered competitors.

5.15: FUEL TANK / FUEL

1. **Types:**
Class A: Either Standard fuel tank or Mandatory Alloy Tank supplied by Go Racing [see 6.1.7] both with standard components fitted to the CB22 model type. Any other fuel tank type and components fitted are prohibited. No modifications are permitted to the standard fuel tank. A non-return valve must be incorporated in the vent system. Note: MOTORSPORT UK regulation Q13.1.4 applies to the CB22 standard model type fuel tank and Mandatory Alloy Tank.
Class B: The standard fuel tank must be retained.
2. **Locations:** Fuel tanks must be mounted in the standard manufacturers position.
3. **Fuel:** Only petrol as defined in Section B Nomenclature & Definitions, **Pump Fuel a)** section of the MOTORSPORT UK Yearbook for the current year and complying with BSEN228 may be used; fuel which exceeds the stated RON (max) levels in Appendix 1 of Section B Nomenclature & Definitions is prohibited even if it is sold/promoted as being legal for UK Competition and/or obtainable from 'roadside' pumps. The use of additives by competitors which boost the octane rating (RON) in any petrol is prohibited. At the end of practice and the race at least 3 litres of petrol from the tank of the competing car must be available to the scrutineers for analysis. Compliance with minimum weight for the car will be taken before the petrol is removed.
Note: The mandatory ECU is designed to run on 100 RON with NO additives.

5.16: SILENCING:

All vehicles must comply with the relevant maximum noise limits set out in MOTORSPORT UK Yearbook regulation J. Chart 5.18.

5.17: NUMBERS & CHAMPIONSHIP DECALS

1. **Positions:** The race numbers for each rear side window shall be;
 - (i) A minimum of 200mm high
 - (ii) With a stroke width of at least 20mm
 - (iii) Coloured reflective yellow.



In addition, the windscreen of all cars must display the competition number positioned on the upper area of the passenger's side of the windscreen, as follows;

- (i) The numerals must be at least 150mm high
- (ii) Be in the same colour and font as those displayed on the rear side windows
- (iii) Be placed no closer than 50mm from the lower edge of the windscreen "sun-strip" and 50mm from the side edge of the windscreen.

750 Motor Club decals must be affixed prominently. Series Sponsor's decals (where applicable) must be affixed in or near the positions detailed on any diagram supplied with those decals. Cars will also be required to carry 750MC series decals on front & rear number plates in the normal number plate position. 750 Motor Club and series Sponsor's decals must take preference to any other decals. Failure to comply will render the vehicle and driver ineligible to race.

2. **Suppliers:** Sponsors and Club decals will be available at the first series race in which the vehicle is entered. Competition numbers will be obtained at the competitor's expense.

6. APPENDICES:

6.1.1 ELIGIBILITY GUIDE 182: Renault Clio 182 Cup, model: Clio II, model type: CB22, VIN: VF1CB220F32892321.

6.1.2 ESP. This must be disabled when racing, other details TBA.

6.1.3

Wheelbase: 2485mm + 4mm to - 10mm

Rear Camber: -1°30' ±20'

Rear Track: 1408 ± 2mm Rear Toe: Toe in 0°54' ±50'

Front Track: 1430 ±2mm Front Toe: free.

Front Camber: -1° to -3.5°

Front Castor: 3° ±30'

King Pin: 12°50' ± 30'

Brake Disc Diameters.

Front: 280 mm. Rear: 238 mm

Front Antiroll bar Diameter: 25.2 ±0.05mm . Renault Part Number: 8200104120

Gearbox: Type JC5, suffix 130

Ratios

1st 11:34

2nd 22:41

3rd 28:37

4th 34:35

5th 39:31

Final drive: 15:61

6.1.4 Air conditioning

It is permitted to remove the air conditioning components in the engine bay with the following Renault parts:

1 off 7703002855 M10X Vis Embase

1 off 8200821816 Belt

1 off 7703033159 Nut M6x100

1 off 7700104128 Adjusting Bolt

1 off 7703002680 M8x1 Vis Embase

1 off 7700868118 Support Pump

1 off 8200031832 Bracket Altern C2

4 off 7703002847 Washer

1 off Alternator, Renault Part number 401745451, or of genuine aftermarket equivalent.

The Control Unit in the dashboard must be retained with all the associated wiring.



6.1.5

ECU Supplier. [Mandatory]

The mandatory ECU supplier is K-Tec Racing.

ECU Part Number: KTR GEN90R750 Priced at £850+VAT

K-Tec Racing

Bournemouth Road

Charlton Marshall

Dorset

DT11 9NE

Tel: 01202 820 800

Email:sales@k-tecracing.com

Mandatory ECU Engine sensors: Renault Part numbers.

Water Temperature sensor: 8200561449

Air Temperature sensor: 7700101451

Knock Sensor: 7700866055

Line pressure sensor: 8200121800 or 8200719629

TDC sensor: 8200468645 or 8200647554

Throttle Body: 8200110994

Crankshaft sensor: N/A

Injectors: 7700109254

Fuel pump/sender: 8200057324

EGO [oxygen sensor]:7700107433

6.1.6 Suspension supplier. [Mandatory]

K-Tec Racing Clio Series specification front and rear coil-over

suspension kit [four dampers + four springs] Part Number

KTRSX9005 Priced at £999+VAT, and Front Top Mounts

050/KIT/KTR/002 Priced at £149+VAT.

K-Tec Racing

Bournemouth Road

Charlton Marshall

Dorset

DT11 9NE

Tel: 01202 820 800

Email:sales@k-tecracing.com

6.1.7 Fuel Tank [Optional]

Part Number: 750MC182TNK

K-Tec Racing

Bournemouth Road

Charlton Marshall

Dorset

DT11 9NE

Tel: 01202 820 800

Email:sales@k-tecracing.com

OR

Part Number:8200 264 182

Go Racing Ltd

7 Fleet Marston Farm

Fleet Marston

Aylesbury

HP18 0PZ

Tel: 07773435488

6.1.8 Engine Mountings Supplier. [Optional]

Upper Engine Mount: 030/EXT/ENG/0018, £85.00 + vat

Upper Gearbox Mount: 030/EXT/ENG/0019, £85.00 + vat

Lower Stabiliser Link: 030/EXT/ENG/012, £65.00 + vat

K-Tec Racing

Bournemouth Road

Charlton Marshall

Dorset

DT11 9NE

Tel: 01202 820 800

Email:sales@k-tecracing.com

6.1.9 Wheels

Pro Race 1.2 (Rimstock)

Part Number: 5-2-57040b9

ET40 offset only

Or

Speedline Ruota

Part Number: {insert}

ET40 offset only

Supplier:

K-Tec Racing

Bournemouth Road

Charlton Marshall

Dorset

DT11 9NE

Tel: 01202 820 800

Email:sales@k-tecracing.com

6.1.10 Tyre Supplier. [Mandatory]

Polleysport

Brockenhurst,

Wimblington Road,

Manea, March, Cambridgeshire PE15 0JR

Tel: 01354 688111

6.1.11 Examples of compliant non-OEM Clutches

VALEO – 172/182 Clutch, part number: 801985

HELIX – C2RS Group N Clutch, part number 30-4203

6.1.12 Suspension servicing & repairs

Spax Dampers

SPAX House. Murdock Road,

Bicester

Oxfordshire, OX26 4PL, England.

Tel: 01869 244771.

6.1.13 Details and specifications that enable compliance.

Engine Data:

Block: 7701472059

Crankshaft:7700111886

Piston: B 7700112313

Conrod:7701465146

Flywheel: 8200441371

Cylinder Head: 7701475731

Inlet Camshaft: 7700115267

Exhaust Camshaft: 8200032853

Subframe: 8200107153



Rear Axle: 8200354724

Heatsheilds
7700836471
7700836472
8200336737
7700436959
[8200336738]

Twin rear exhaust: 8200373726.

6.2.1 ELIGIBILITY GUIDE: Renault Clio 197/200, model: Clio III, model type: CR1N.

6.2.2 ESP: N/A

6.2.3
Wheelbase: 2585mm + 4mm to - 10mm

Rear Camber: $-1^{\circ}30' \pm 20'$
Rear Track: 1520 \pm 2mm

Front Track: 1520 \pm 2mm Front Toe: free.
Front Camber: -1° to -3.5°
Front Castor: $5.38^{\circ} \pm 40'$

Brake Disc Diameters.
Front: 312 mm. Rear: 300 mm

Gearbox: Type TL4, suffix 003
Ratios

1st	11:35
2nd	19:37
3rd	29:43
4th	34:41
5th	38:39
6 th	39:34
Final drive:	16:69

Or

Type TL4, suffix 024
Ratios

1st	11:35
2nd	19:37
3rd	29:43
4th	34:41
5th	35:34
6th	37:30
Final drive:	16:69

Or

Type TL04, suffix 031
Ratios

1st	11:37
2nd	19:40
3rd	27:41
4th	34:41
5th	35:34
6th	37:30
Final drive:	16:69

6.2.4 Air conditioning

It is permitted to remove the air conditioning components in the engine bay with the following parts supplied by K-Tec Racing:

ING/BLT/013A

6.2.5

ECU Supplier. [Mandatory]

The mandatory ECU map is supplied by K-Tec Racing.

K-Tec Racing
Bournemouth Road
Charlton Marshall
Dorset
DT11 9NE

Tel: 01202 820 800
Email:sales@k-tecracing.com

6.2.6 Suspension

K-Tec Racing Clio 197/200 Series specification front and rear coil-over suspension kit [four dampers + four springs] Part Number 050/KIT/SPX/0014 and Front Top Mounts (x2) Part Number: 050/KIT/KTR/0016
Powerflex Front Lower Arm Bush: 030/MOU/PFX/020A
Powerflex Rear Lower Arm Bush: 030/MOU/PFX/022A
Powerflex Rear Beam Mounting Bush: 030/MOU/PFX/027A

K-Tec Racing
Bournemouth Road
Charlton Marshall
Dorset
DT11 9NE

Tel: 01202 820 800
Email:sales@k-tecracing.com

6.2.7 Exhaust

Sports catalytic converter: 040/KTR/197/K08
Front pipe: 040/KTR/CL3/0006
Mid link pipe: 040/KTR/CL3/0002
Twin rear silencer: 040/KTR/CL3/0003
Tail pipes: 040/KTR/CL3/0005

KTR Clio 3RS Pro Performance Sports Cat - 1134
KTR Clio 3RS 197 Sports Catback Exhaust System - 2660
KTR Clio 3RS 200 Sports Catback Exhaust System - 3658

Supplier:
K-Tec Racing
Bournemouth Road
Charlton Marshall
Dorset
DT11 9NE

Tel: 01202 820 800
Email:sales@k-tecracing.com

6.2.8 Engine Mountings

Upper Engine Mount: 030/EXT/ENG/0011
Upper Gearbox Mount: 030/EXT/ENG/0012
Lower Stabaliser Link: 030/EXT/ENG/013

Supplier:
K-Tec Racing
Bournemouth Road
Charlton Marshall
Dorset
DT11 9NE

Tel: 01202 820 800
Email:sales@k-tecracing.com



6.2.9 Wheel Supplier. [Optional]

Part Number: 080/SPL/197/002
ET68 offset only.
K-Tec Racing
Bournemouth Road
Charlton Marshall
Dorset
DT11 9NE

Tel: 01202 820 800
Email:sales@k-tecracing.com

6.2.10 Tyre Supplier. [Mandatory]

Polleysport
Brockenhurst,
Wimblington Road,
Manea, March, Cambridgeshire PE15 0JR

Tel: 01354 688111

6.2.11 Examples of compliant non-OEM Clutches

HELIX – C3RS Uprated Organic Clutch, part number
060/CLU/C3R/001 (Cover) + 060/CLU/C3R/002 (plate)

6.2.12 Suspension servicing & repairs

Spax Dampers
SPAX House. Murdock Road,
Bicester
Oxfordshire, OX26 4PL, England.

Tel: 01869 244771.

6.2.13 Axle Strengthening Kit

Part Number: 030/PUR/BEA/0044

Supplier:
K-Tec Racing
Bournemouth Road
Charlton Marshall
Dorset
DT11 9NE

Tel: 01202 820 800
Email:sales@k-tecracing.com

. ITS VERY SIMPLE, IF IN DOUBT ASK.

Please make contact with the 750MC if you have any queries regarding these regulations. They are the only people who can definitively provide the answers required to your questions.



6.7: Drawings

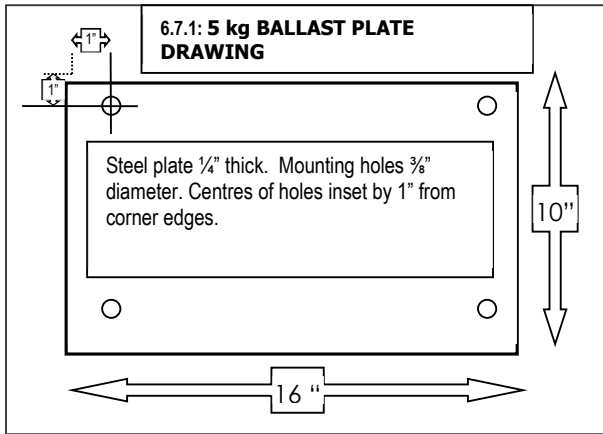

6.7.3 TOP MOUNT PLATE POSITION [Ref:5.8.1.1]

Nearside View.

Dimensions in mm
 Tolerance +/- 0.5mm

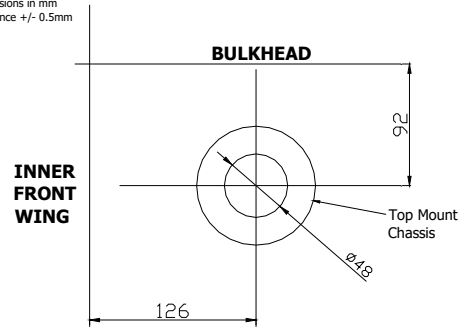

Repeat Mirror image for OFFSIDE.

6.7.2 TOP MOUNT PLATE [Ref:5.8.1.1]

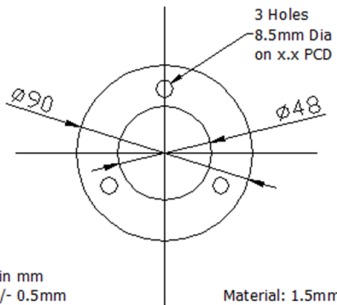

Dimensions in mm
 Tolerance +/- 0.5mm

Material: 1.5mm thick steel.

'x.x PCD' is 63.0mm +/- 0.1 mm

Guidance Notes (CLASS A – 182).

The Model type and especially the Vin must be used to ensure the competitors vehicle conforms to the regulations, and can also be used to acquire the correct spare parts.

The control ECU is designed and programmed to provide the optimum engine performance with the sensors listed, and with a standard component engine with a compression ratio of 11:1, running on pump fuel. By not using the specified standard parts or deviating in any way the engine performance will be reduced, and may result in permanent damaged. Also the ECU is capable of Data-logging, with most of the data being available to Scrutineering only. It is also capable of providing the competitor with fault coding and certain other data.

The series requires the eligible car to be the 182 CUP variant, however a 182 sport can be used provided the CUP options are fitted, pertaining to the Front Suspension Hubs, flanges, and drive-shafts and rear wing. Other 'CUP' requirements on trim and accessories are not perceived as relevant and thus do not need to be evident.

It is NOT considered viable to upgrade 172 type cars to the 182 CUP requirement.

Air conditioning, as stated can be removed, but only the compressor and radiator and associated piping in the engine bay. A kit of replacement parts is listed as mandatory to provide a reliable and compliant modification so each car is the same and easily policed. There are 'other' kits and methods that have and are proving to be very un-reliable and damaging engines when used in motorsport.

ESP must be disabled when racing, and at the moment this has to be selected by the driver, until a secure method is found.

ABS, two options its either you comply to option 1 or option 2 there is no combination allowed. The facts have confirmed the original concern and thus its either full standard ABS or Non ABS but the fitting of a mandatory brake bias valve for the rear brakes to avoid lock up but also to comply with MOTORSPORT UK regulations requiring the 25% braking to the rear wheels. The ABS ECU will remain operational with both options, and the standard wheel sensors have to be fitted and working. The Engine ECU uses the wheel sensor data and ABS ECU interface, and Scrutineering can access this data to ensure function and gearbox/final drive ratio.

Gearbox ratios are stipulated, so ensure the gearbox fitted is the correct type JC5 suffix 130, as it can be checked electronically.

There are 'other' useful Renault part numbers listed in this document to determine the exact part requirement for the race car eligibility.

Fuel surge – fuel surge is an issue when running very low fuel levels – however, it has been noted that some cars do suffer fuel surge with 10+ litres in the fuel tank. If you're suffering with fuel surge then a previously successful fix is to replace the fuel pump with an OEM product.

Engine mounts: It is clear the standard engine mounts do degrade over racing, so the option to use upgraded types is allowed, as well as standard, but it is either/or, no combinations.

Clutch type (Classes A & B) – for clarification:

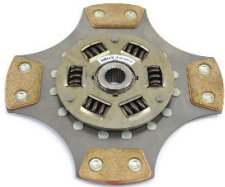

Not within Regulations



Within Regulations



Handwritten signature or initials.