



1 SPORTING REGULATIONS - GENERAL

1.1 TITLE & JURISDICTION

The **BMWCCR Championship** is organised and administered by the 750 Motor Club Ltd and the BMW Car Club GB in accordance with the National Competition Regulations (NCR's) of Motorsport UK (incorporating the provisions of the International Sporting Code of the FIA) and these Championship Regulations.

- 1) **MOTORSPORT UK Championship Permit No: CH2026/035**
- 2) **MOTORSPORT UK Championship Grade: C**
- 3) **Race Status:** Inter Club.

This document defines the specific Championship regulations and structure of the Championship for both fair and safe competition and are to be adhered to by all Entrants and Drivers at all times.

The Organisers reserve the right to amend or clarify these Championship Regulations at any time during the season by way of publication of Official Championship Bulletins issued in accordance with NCR Ch. 3 App. 10 Art 4.2 and subject to Motorsport UK approval.

1.2 OFFICIALS

- 1) **Championship Co-Ordinator:** Giles Groombridge, The 750 Motor Club, Donington Park, Castle Donington, Derbyshire. DE74 2RP.
- 2) **Championship Eligibility Scrutineer:** S. Dockray, Deputy: B. Blackmore
- 3) **Championship Stewards:** I. Sowman, P. Brough, M. Smith, T.Stevens

Any three Championship Stewards will constitute a quorum. In the event of any of the Championship Stewards listed above being unavailable or being unable to consider any particular matter due to a perceived conflict of interest, the organisers reserve the right to appoint an alternative Championship Steward or, if deemed to be necessary, more than one alternative Championship Steward. NCR Ch.4 App.1 Art.1.2. The Championship Stewards can only adjudicate upon any disputes irregularities or appeals arising from the published Championship Regulations. They are also empowered to consider any request from the Championship Coordinator to penalise any Competitor for any breach of Championship Regulations and after holding a formal hearing those Stewards may impose a penalty in accordance with NCR Chapter 2 subject to the rights of Appeal to the National Court.

- 4) **BMW Car Club Representative:** Neil McDonald

1.3 COMPETITOR ELIGIBILITY

- 1) Entrants must:
 - a) be fully paid-up valid members of the 750 Motor Club.
 - b) Be Registered for the Championship.
 - c) Be in possession of a valid Motorsport UK Entrants Licences.
- 2) Drivers and Entrants must:
 - a) Be current Members of the 750 Motor Club.
 - b) Be registered for the Championship and
 - c) Be in possession of a valid Competition (Racing) Club Licence, as a minimum
 - a) Or be in possession of the highest grade of national Race licence or valid FIA International Licence including confirmation of a valid medical certification, together with their ASN's written consent (Motorsport UK National Competition Rules (NCR) Ch.6 App.3 Art.1 and FIA ISC Article 2.3.7.b applies)
 - d) If participation in the Championship requires absence from education a driver, in full time school education is required to have the approval of their head teacher and a letter stating such approval from their school in order to fulfil registration for the Championship. A driver shall not take time out of education to participate in motor sport without prior written approval of their education establishment.



- 3) All necessary documentation must be presented for checking at all rounds when signing-on. All competitors must sign-on at Events that they compete in and all necessary documentation must be available to be presented for checking at all times upon the demand of the Officials.
- 4) All drivers are encouraged to be members of the BMW Car Club GB.

1.4 REGISTRATION

- 1) All competitors must register for the Championship by returning the Registration Form with the Registration Fee to the Coordinator prior to the Final Closing date for the first round being entered.

All competitors must submit a power graph from one of the approved rolling roads listed in section 10 indicating power at wheels and flywheel (see section 10.) This must be provided by email in a PDF format to neil@bmwclubgb.co.uk

- 1) The Registration Fee is £195 payable upon registration. For competitors wishing to enter a single event a registration fee of £50 is payable; if further races are entered the balance of the £195 fee must be paid.
- 2) Registration numbers will be the permanent Competition number for the Championship

1.5 CHAMPIONSHIP ROUNDS

The **BMWCCR Championship** will be contested over the following rounds*:

Date	Circuit	Round/s
18 April	Brands Hatch	2
10 May	Silverstone Nat	2
31 May	Donington Park	2
25 July	Oulton Park	2
31 August	Snetterton 300	2
26 September	Thruxton	2
18 October	Donington Park GP	2

* subject to valid track licences being in place

If a minimum of 16 entries is not reached by close of entries, the Organisers reserve the right to amalgamate races/classes or cancel races.

1.6 SCORING

- 1) Points will be awarded to Competitors in each class listed as classified finishers in the Final Results as follows: - **12**;10; **9**; 8; 7; 6; 5; 4; 3. 2 Other finishers 1. Fastest lap per class - 1 point subject to a minimum of 2 starters in class.
- 2) All official starters will receive 2 points, which will not be dropped from a driver's final championship points.
- 3) The totals from all qualifying rounds run (excluding any races which are abandoned, and which are not replaced) less 2 will determine the final championship points positions. Where a competitor is required to drop 1 or more scores, the points received for starting a race (see 1.6.2) will be retained and only those received for finishing a race will be dropped.
- 4) If there are less than 4 starters in any class points will be awarded to Competitors listed as classified finishers in the Final Results as follows: **6**; 5; 4; 3; 2.
- 5) If there are 3 starters or less in any class, excluding M1, **M2 Racing** & Cup, they will compete in a higher class.
- 6) Drivers competing in the BMWCCR Championship can receive two bonus championship points for completing a full day marshalling at a 750 Motor Club Event prior to the final round of the BMWCCR season. These bonus points can be accrued during the season and will be added to the drivers points for starting a race (see 1.6.2) which must not exceed a total of 28 points in a given season.
- 7) Ties shall be resolved using the formula in NCR Ch.4 App.3 Art.4
- 8) Where the race distance has been reduced (2.6.) it shall still count as a full points scoring round.



- 9) Competitors not registered for the Championship may be permitted to compete on an individual round basis as a guest. Any guest drivers must be specifically invited and/or approved by the championship organisers and will:
- not score points and for the purpose of points scoring will be ignored
 - not qualify for Event awards
 - comply with the eligibility criteria as prescribed in Article 1.3. above, with the exception of 1.3.1. (b) and 1.3.2. (b), as appropriate

1.7 AWARDS

- All awards are to be provided by the Organising Club unless agreed otherwise.
- Per Round: Trophies to 1st, 2nd and 3rd.
- Championship: Trophies, subject to a minimum of 5 race starts, to: - 1st, 2nd & 3rd overall, 1st, 2nd, 3rd in each class.
- Presentations: Awards will be presented at the end of each event, and/or at the end of the Championship at the designated presentation ceremony.
- Entertainment Tax Liability: {deleted}
- If Provisional Results or Championship Tables are revised after any presentations and these revisions affect the distribution of awards the Competitors concerned must return them to the organisers in good condition within 7 days.

2. CHAMPIONSHIP EVENTS & RACE PROCEDURES

1 ENTRIES

- Competitors are responsible for sending in correct and complete entries with the correct entry fee prior to the closing date for entries before each event.
- Incorrect or incomplete entries (Including Driver to be Nominated Entries) are to be held in abeyance until they are complete and correct and the date of receipt for acceptance of entry purposes shall be the date on which the Event Organiser receives the missing or corrected information or fee.
- Any withdrawal of Entry or Driver/Vehicle changes made after acceptance of any entry must be notified to the Event Organisers in writing. NCR Ch.3 App.11 Art.1.1 applies.
- The Entry Fee for each event shall be specified in the SRs and on the entry form.
- Reserves will be listed in the Final List of Entries published with Final Instructions or in a Bulletin.

2 BRIEFINGS

Organisers will notify Competitors of the times and locations for all briefings in the Final Instructions for the Events. Competitors must attend all briefings. Any Written briefing is an Official Document.

3 QUALIFICATION PRACTICE

- Should any Practice session be disrupted the Clerk of the Course shall not be obliged to resume or re-run the session; the decision of the Clerk of the Course shall be final.
- Each driver **shall must** complete a minimum of 3 laps in the vehicle to be raced, and in the correct session, in order to qualify (NCR Ch.12 App.6 Art.3.1.
- At Double Header Events the Grid for Race 2 will be set by the finishing positions in Race 1.
- At Triple Header Events the grid for Race 3 will be set by the finishing positions in Race 2.

4 RACES

Should any race be disrupted the Clerk of the Course shall not be obliged to resume or rerun the race (NCR Ch.12 App.6 Art.9 (1.6.4. above applies)

5 STARTS

- All vehicles will be released to form up on the grid prior to the start in formation as specified on the grid sheet.
- The start will be via Standing start. The minimum Countdown procedures/audible warnings sequence shall be:-



- i) 1 minute to start of Green Flag/Pace Lap - Start Engines/Clear Grid.
 - ii) 30 Seconds - Visible and audible warning for start of Green Flag Lap.
 - iii) A five second board will be used to indicate that the grid is complete.
 - iv) The red lights will be switched on five seconds after the board is withdrawn.
- 3) Any vehicle removed from the grid after the 1-minute stage or driven into the pits on the Green Flag lap shall be held in the pitlane and may start the race after the last vehicle has passed the startline or pitlane exit, whichever is the later to take the start from the grid.
 - 4) Any driver unable to start the Green Flag Lap or start are required to indicate their situation as per NCR Ch.12 App.6 Art.6.11. In addition, any driver unable to maintain grid positions on the Green Flag Lap, to the extent that ALL other vehicles are ahead of them, may complete the Green Flag lap but MUST remain at the rear of the last row of the grid but ahead of any vehicles to be started with a time delay.
 - 5) In the event of any starting lights failure the Starter will revert to use of the National Flag.

6 SESSION RED FLAG

Should the need arise to stop any race or practice; RED LIGHTS will be switched on at the Startline and RED Light panels / FLAGS will be displayed at the Startline and at all Marshals Signalling Points around the Circuit. This is the signal for all drivers to cease circulating at racing speeds, to slow to a safe and reasonable pace and to return to the pit lane, **during practice**, and to the starting grid area, **during a race**, unless otherwise directed by officials. Vehicles may not enter the Pits unless directed to do so. Work on vehicles already in the Pits must cease when a race is stopped. Marshals should revert to displaying yellow flags to indicate to Drivers the particular location of any incident hence supplementing the Light Panels.

7 PITS, PADDOCK & PITLANE SAFETY

- 1) **Pits & Paddock:** Competitors must ensure that the MOTORSPORT UK, Circuit Management and Organising Club Safety Regulations are complied with at all times.
- 2) **Pitlane:** The outer lane or lanes are to be kept unobstructed to allow safe passage of vehicles at all times. The onus shall be on all Drivers to take all due care and respect the pit lane speed limits.
- 3) **Refuelling:** May only be carried out in accordance with the MOTORSPORT UK, the Organising Club Regulations, Circuit Management Regulations and the SRs or Final Instructions issued for each Circuit/Event.
- 4) **Speed Limit:** Pit Lane Speed Limit will be 60 km/h unless otherwise stated by the circuit or as notified in the Final Instructions for the Event/Event.

8 RACE FINISHES

After taking the Chequered Flag drivers are required to:

- 1) progressively and safely slow down,
- 2) remain behind any competitors ahead of them,
- 3) return to the Pit Lane Entrance/Paddock Entrance as instructed,
- 4) comply with any directions given by Marshals or Officials,
- 5) keep their helmets on and harnesses done up while on the circuit or in the pitlane.

9 RESULTS

All Practice Timesheets, Grids, Race Results are to be deemed Provisional until all vehicles are released by Scrutineers after Post Practice/Race Scrutineering and/or after completion of any Judicial or Technical Procedures. NCR Ch.3 App.6 Art.1.4.

10 TIMING MODULES

The 750 Motor Club utilises transponder-based timing and competitors must have a compatible transponder fitted and working and advise the race organisers of its number prior to the event. Compatible transponders include the AMB TRANX 260 and MyLaps X2 & TR2 models.

11 QUALIFICATION RACES

If any event is oversubscribed the Organising Club may at their discretion run Qualification Races.



12 OPERATION OF SAFETY CAR

The Safety Car will be brought into operation and run in accordance with NCR Ch.12 App.8 Art.2.

13 ONBOARD CAMERAS

All competitors are required to carry an on-board front facing, in car camera that records to an SD (or micro-SD) card that can be played back on a standard laptop and high enough quality for judicial purposes. Recordings from the cameras may be used where there is an incident which is subsequently brought before the Clerk of the Course for investigation.

Where forward facing cameras are fitted for judicial purposes, they should be mounted so as to capture an image that provides a 'driver's eye' view that should include, where possible, the steering wheel, 'dashboard' and a view of the circuit ahead with a field of vision of approximately 100 degrees.

It is the competitor's sole responsibility to ensure safe installation and effective operation of the camera equipment. At all times cameras must be fitted in accordance with MOTORSPORT UK NCR and be approved by the Chief Scrutineer in accordance with NCR Ch.7 App.9.

Cameras must be mounted in a position such that the steering wheel and track in clear view. The unit must always be switched on and be recording when the vehicle is on track during any official free practice, qualification session and race.

The onus is on the competitor to ensure that the camera unit battery is charged, the camera switched on to record and manage the storage to ensure enough space is available on which to record during the above-mentioned sessions. The onus is on the competitor to ensure that the camera unit battery is charged, the camera switched on to record and ensure the SD card has enough capacity to record the above-mentioned sessions. The SD card must ONLY contain the files from the event in question. The penalties below also apply.

In the event that no recording is available when requested by the Organisers or Clerk of the Course for judicial purposes then warnings will be issued by the Clerk of the Course for the 1st and 2nd offences which will as a consequence incur the following championship penalties. ~~then the following penalties will be applied by the Clerk of the Course.~~

- a. First offence – Championship Reprimand One Championship Point Deducted
- b. Second Offence – Four Championship Points Deducted – Equivalent to a 5th an 8th place finish.
- c. Third Offence – Disqualification from the race or practice session.

3 SPECIFIC CHAMPIONSHIP REGULATIONS

- 1) By registering for the Championship all competitors and their associates commit to positively promote and demonstrate the Motorsport UK's Respect Code which can be found on the Motorsport UK website.

Where any reports of disrespectful conduct are judged to be well founded the Championship organisers may issue warnings or require remedial actions and/or report the matter to the Championship Stewards who may impose appropriate penalties which can include loss of Championship points and/or race bans through to Disqualification from further participation in the Championship Expulsion and referral to Motorsport UK.

It is imperative that we promote the safety and wellbeing of young people and adults at risk. In addition to this all participants must be aware of their behaviour and conduct at all times and abusive language and harmful behaviour will not be tolerated. Any such incidents must be reported to the Championship Coordinator and/or Safeguarding Officer who will also relay the report Motorsport UK. Details of the Motorsport UK Policies and Guidelines are available at www.motorsportuk.org/resource-centre by selecting Policies and Guidelines.



- 2) In the event of any rounds being oversubscribed the Organising Club may, in liaison with the Championship Coordinator, at their discretion run Qualification races as per 2.11 of these regulations. Alternatively, at double header race Events, should there be sufficient space within the timetable; the Organising Club may divide the grid after qualifying into 3 separate Groups. The Groups will then form 3 races whereby each competitor participates in two races. All 3 races will be eligible for full championship points.

At each Round of the championship Race 1 grid positions will be determined by each competitors fastest lap time in Qualifying. At double header Events, the grid positions for Race 2 will be determined by the finishing positions in Race 1

- 3) The Championship co-ordinator reserves the right to request the fitting of a 750MC owned data logging system to any vehicle prior to competition. Failure to comply will result in disqualification.
- 4) The aim of the BMWCCR Championship is to provide amateur drivers a cost-effective environment to enjoy racing a BMW. Consequently, Professional Drivers will only be allowed to compete as an Invitational entry.

A Professional Driver is defined as: A driver under 60 years of age who either:

- a) Has a "Silver" or "Gold" ranking on the FIA Drivers Categorisation List
- b) Has qualified for full BRDC membership or is/been a BRDC "Rising Star" or "Superstar."
- c) Has earned money in the past 12 months as a racing driver.
- d) Has raced in the BTCC or as a "Pro" in British GT in the past 5 years.

The organisers decision on a Driver's "Professional" status is final.

- 5) Drivers who are still required to display a novice cross will not be permitted to race in Class M1.
- 6) Upon request from the BMWCCR Committee drivers are required to provide their in-car footage (in the format as described in section 2.13 above) for review. This is to enable the committee to be able to provide support with driving standards.

4 SPECIFIC CHAMPIONSHIP PENALTIES

In accordance with the current NCR Chapter 2

4.1 INFRINGEMENT OF TECHNICAL REGULATIONS

- 1) Arising from post practice Scrutineering or Judicial Action: Minimum Penalty:
The provisions of NCR Ch.2 App.8.
- 2) Arising from post-race Scrutineering or Judicial Action: Minimum Penalty:
The provisions of NCR Ch.2 App.8.
- 3) For infringements deemed to be of a more serious nature the Clerk of the Course will invoke the provisions of NCR Ch.2 App.8 Art.2

4.2 ADDITIONAL SPECIFIC CHAMPIONSHIP/SERIES REGULATIONS

In the case of a driver being disqualified from a race, the Clerk of Course will impose the penalties set out in NCR Ch.2 App.8 and may impose the penalty set out in NCR Ch.2 App.8 Art.2.

- 1) In order to maintain standards of conduct, the Championship Organisers will monitor all Officials/Observers reports of adverse behaviour at race Events. If any individual is included on two such reports during one racing season the Championship Organisers will request the Clerk of Course at future race Events to consider specific observation of that driver's conduct.
- 2) The Clerk of Course may impose a "Stop-Go" or "Drive through" penalty during a race in accordance with NCR Ch.12 App.10 Art.2.



- 3) Any Competitor who is penalised under the Championship Sporting Regulations at any stage of a Championship event and receives an allocation of penalty points on their race license in accordance with NCR will receive a Championship points deduction equal to the number of penalty points which were allocated. Should the same competitor receive penalty points at another round of the Championship then the number of Championship points deducted will be double the number of penalty points applied. If penalty points are applied at a third round, then the Championship points deducted will be triple this number, and quadrupled at the fourth occurrence of such a penalty etc. This may result in a driver receiving a negative score.
- 4) Championship Stewards are also empowered to consider any request from the Championship co-ordinator to penalise any Competitor for any breach of Championship regulations and, after holding a formal hearing if they deem it necessary, to impose a penalty in accordance with NCR Ch.2 App.2 Art.4 (subject to the rights of appeal provided for in NCR Ch.2 App.5 Art.1)
- 5) One or more of the following may be imposed by the Championship Stewards as appropriate.
 - a) Reprimand
 - b) Fine. This may be also applied in the case of a driver receiving three reprimands from the Championship Stewards in one season.
Time or Grid Penalties
 - c) ~~Suspension from all or part of the Championship. This may also be applied in the case of a driver receiving two fines from the Championship Stewards in one season. Disqualification from further participation in the Championship, NCR Ch.2 App.2 Art 4.1~~

5 TECHNICAL REGULATIONS

5.1 INTRODUCTION

- 1) The following Technical Regulations are set out in accordance with the MOTORSPORT UK NCR specified format and it should be clearly understood that; **if the following texts do not clearly specify what modifications or upgrades can be made to the vehicle, then you must work on the principle that it will not be permitted.** The fact that some modifications are mentioned as prohibited does not imply that others are allowed. If any doubt exists about the legality or acceptability of any modification, then please request clarification from the Championship Coordinator **prior** to any work being undertaken.
- 2) **STANDARD:** The word 'standard' used within these technical regulations as a description of components is to be interpreted as per 'Standard Part' defined in NCR Ch.1 App.1. Checking will be by comparison to spare parts supplied by the manufacturer's official agent or by any other means necessary to ensure compliance.
- 3) **STANDARD PATTERN:** The phrase 'standard pattern' used within these technical regulations as a description of components is to be interpreted as per 'Standard Part' defined in NCR Ch.1 App.1. Checking will be by comparison to spare parts supplied by the manufacturer's official agent or by any other means necessary to ensure compliance.

5.2 GENERAL DESCRIPTION

- 1) The BMWCCR is for competitors participating in any model produced by BMW AG for sale or approved for use in the European market to the general public as shown in sales brochures available through the UK or European dealer network. Vehicles must have a BMW engine fitted.

The BMWCCR and BMWcup technical regulations are intended to allow competitors to produce race cars that are safe, affordable and of a near identical level of performance, with the emphasis placed firmly on driver ability. Competitors are therefore asked to keep this in mind when building or modifying race cars and are encouraged to seek guidance from the Championship Co-ordinator where appropriate.

BMWCCR currently consists of ~~6~~ 5 classes M1, M2, 6, M2 Cup, BMWcup and 4 with the option of guest entrants placed in an "Invitational" class.



Each class (excluding [M2 Cup](#) & BMWcup) will be differentiated by engine power (at FLYWHEEL) and specification with an offset for aerodynamics. Minimum weights will apply to each class.

- 2) Examination of vehicles. The Championship Eligibility Scrutineer (in addition to any other powers they may have under these regulations) reserve the right before or after any race in the Championship to designate any one or more of the competing vehicles for special eligibility scrutineering. Competitors must be prepared, with tools and spare parts as necessary, to enable inspection of components, or to have units sealed at the circuit for later inspection by the Eligibility Scrutineer at the Competitor's expense.

Upon such selection being made the competitor shall immediately place the vehicle under the control of the Eligibility Scrutineer and be deemed to have permitted all such scrutineering, examination and testing as the organisers may reasonably require. The Eligibility Scrutineer has the right to:

- a) Examine the vehicle at the circuit for such period as they may reasonably require and take fuel samples.
- b) Retain the vehicle for detailed examination at premises chosen by the scrutineer, if the scrutineers elect to retain the vehicle, they shall make it available for collection by the competitor at least seven days prior to the qualification session for the next race in the Championship unless the vehicle is found to be in breach of these regulations.
- c) Seal the vehicle and any of its components in such a manner as they may choose and require the competitor at their own expense to present the vehicle at any other premises chosen by the organisers for detailed examination within a specified period and / or remove the vehicle by transporter at no expense to the competitor to an appointed location. The competitor will be advised in writing of the time, date and location of the subsequent testing or eligibility examination.

The overseen stripping of the engine or any required component will be undertaken by the competitor and / or mechanic / technician nominated by the competitor.

- d) The scrutineer can at their discretion request the removal of any part for their further inspection and testing. If the scrutineer decides to retain any part for further inspection over a race weekend, a fully eligible replacement part will be provided by the scrutineer at the time of removal, allowing the competitor to continue racing.
- e) Request the competitor agrees to place their vehicle on the club's nominated mobile dyno or seal the vehicle and have the vehicle tested on a Championship nominated Dyno.
- f) In summary, declared vehicle powers may be verified in any number of ways during the season – these will include the following:
 - i) Rolling road – at the circuit
 - ii) ECU downloads
 - iii) Fitting of a VBox or similar by the organisers
 - iv) Sealing the engine before or after the Event
 - v) Request to visit an alternative Rolling Road

If a vehicle is tested after competition, then the operating area for the power test will be subject to parc ferme conditions, this includes the route from the pit lane or parc ferme to the power testing location and the route back to parc ferme. Alternatively, the organisers reserve the right to seal a vehicle and send it to one of the championship designated rolling road centres for testing. If requested the organisers may also either seal or remove a vehicles ECU and reunite it with the vehicle at the designated test centre. Failure to comply will result in disqualification

5.3 SAFETY REQUIREMENTS

NCR Ch.7 Competitor Vehicles and Vehicle Safety Equipment and Ch.9 Competitor Personal Safety Equipment (PPE) will apply.

Specifically:

Six-point roll cage to a minimum of drawing NCR Ch.7 App.13 Safety Cage Drawings Diagram 14 or 15



Optional reinforcing members NCR Ch.7 App.13 Safety Cage Diagrams 21(a), (b), (d), (g) and (j) are permitted

Cages that connect to the front suspension anchorage points as per NCR Ch.7 App.13 Safety Cage Drawings Diagram 20 are optional.

Ch.7 App.2 General Technical Regulations
Ch.7 App.3 Roll Over Protection Systems (ROPS);
Ch.7 App.4 Fuel Systems
Ch.7 App.5 Electrical Systems
Ch.7 App.6 Fire Extinguisher Systems
Ch.7 App.7 Seats Harnesses and Headrests;
Ch.9 Competitor Personal Safety Equipment (PPE)

Seat belts as per Ch.7 App.7, **4-point harnesses are not permitted.**

Extinguishers must be plumbed in and comply with NCR Ch.7 App.6

Towing eyes must comply with National Competition Rules (NCR) Ch.12 App.13 Art.1.3 & 1.4

5.4 GENERAL TECHNICAL REQUIREMENTS & EXCEPTIONS

All cars must comply with the requirements of sections NCR Ch.7 and Ch.12 App.13. All vehicles must be of sound construction and mechanical condition and be well maintained. Water hoses, oil hoses and their associated clips are free. Fasteners (e.g. nuts, bolts) are free. The organisers reserve the right to refuse entry from any car of which the preparation is of a poor standard (including the external appearance) and which is likely to bring the championship into disrepute. A ~~naturally aspirated~~ BMW engine can be fitted to any model (EXX / FXX) in M1, M2, 6 and 4.

Class Structure/Detail:

M1:

Power and weight of the car with fuel and driver will be calculated following a visit to a nominated rolling road. No max. cubic capacity (refer to chart for conversion and limits) but standard engine capacity may only be increased by a maximum 2%

Whilst the organisers want to see cars be developed there remains an overarching desire to level the playing field and make it possible for drivers with lower budgets to still compete with those on bigger budgets. A minimum weight of 1080kg will apply inc. driver.

Transmission internals must remain original for the type and model of BMW gearbox fitted (synchromesh or SMG.)

Engines to retain original position within engine bay in relation to standard subframe/bulkhead – dry sump allowed following approval.

For cars powered by naturally aspirated engines, in attempt to deter cheque book racing, for expensive high compression engines with very high mid-range power a new sliding scale handicap will apply. This measure is not designed to affect a normally mapped naturally aspirated engine which should avoid this penalty altogether. Previously, minimum weight was dependent solely on peak power at the flywheel. Now, drivers will be asked to declare the peak power at the flywheel and the power at 5000rpm (also at the flywheel). The minimum weight is listed in the chart in appendix 11 and is based on the cars specific “power figure”: This “power figure” used to calculate minimum weight for the car will be derived according to the following formula:

(Peak power at the flywheel) OR (1.21 x power at flywheel at 5000rpm) whichever is the greater



For avoidance of doubt if an engine makes 400BHP peak and 330 BHP at 5000 rpm then 1.21 x 330 = 399 and minimum weight will STILL be based on 400BHP. But if an engine makes 400 BHP peak and 340 BHP at 5000 rpm then 1.21 x 340 = 411hp and thus minimum weight will now be calculated based on 411BHP not 400BHP. Competitors are free to remap their cars accordingly prior to declaring their peak and 5000rpm figures.

Thus, the handicap gradually kicks in, but only if an engine has an extremely flat power curve (regardless of the reason – be it high comp pistons, turbos or a deliberate mapping). The club is always looking for ways to discourage cheque book racing and allow low budgets to compete with high budgets. Equally we do not wish to exclude highly developed cars; instead, we have attempted to devise a fair handicapping system. For this reason, expensive high compression engines are only eligible for BMWCCR as long as they do not have a performance advantage versus a well set up car with a cheap standard engine. The rule changes attempt to future proof the M1 class from expensive or unfair competition. If you think it affects you or wish to have it explained further, please contact the Championship Coordinator

M2:

For cars powered by naturally aspirated MXX or NXX engines the power and weight of the car with fuel and driver will be calculated following a visit to the rolling road. Maximum 3000 cubic capacity engines (see chart for calculations) or ask organisers for an agreed figure. Minimum weight 900kg inc driver after the race. For the avoidance of doubt SXX designated engines are not permitted with the exception of the S14.

Transmission internals (gears/synchro/ratios) must remain original for the type and model of BMW gearbox fitted (synchromesh or SMG.)

Class 6:

Power and weight calculated as in other classes. Maximum 2999cc 6 cylinders. Aimed at MXX & NXX standard engines and induction. Standalone/aftermarket ECUS are not permitted. Minimum weight 1000kg inc driver after the race. Forced Induction vehicles are not permitted in Class 6.

To illustrate the differences in permitted modifications between M2 and Class 6, please see the table below:

	Class 6	Class M2
Air Filters	After market induction kits or air filters permitted up to air mass	Permitted
ECU	BMW Standard ECU (remap permitted)	Standalone/Aftermarket permitted
Throttle bodies	Standard OEM fitment to chassis	Permitted
Airbox	Aftermarket or CSL air boxes are not permitted	Permitted Aftermarket or CSL air boxes are not permitted
Air Mass Meter / Air Flow Meter	Functional original spec BMW fitment	Open
CAMS	Standard Original Spec unmodified fitment	Reprofiled and aftermarket permitted
Tyres	Max width 245	Max width 255
Rear Aero	BMW OEM or copy, BMW GT, DTM, M3 Cup, STW, position not modified or extended	Max size mm (1420x340x350) exc end plates
Suspension	OEM, 1 or 2 way	3-way
Panels	Lightweight boot, bonnet, bumpers & wings permitted	Lightweight panels permitted
Roof	Original or OEM panel Carbon/composite roof permitted	Carbon/composite roof permitted





Doors	<u>Fibreglass permitted</u>	Fibreglass permitted
Engine Internals	OEM Engine internals/parts	OEM Engine internals/parts
Engine to Chassis	Engine model in period	BMW Engine period does not need to match chassis
Min Weight	1000 kgs	900kgs

BMW M2 Cup:

BMW M2 Cup specific regulations apply – see appendix 2

BMWcup:

Controlled standard MS43 ECU E46 325 (all body types) (BMWcup specific regulations apply) – see appendix 1

Class 4:

Power and weight calculations will apply based on performance, 4 or 6 cylinder engines, M or N designation, standard ECU. Minimum weight 900kg inc driver. Forced Induction vehicles are not permitted in Class 4.

Invitation:

Invitation class – Any BMW model – can run invited by the club or who don't wish to register (see section 1.6.9)– or the does not fit a current class or the club wishes to assess for class allocation (use of 1B 1C tyres is allowed for first invitation race) – power and weight to be agreed with BMWCCR Committee.

5.5 CHASSIS

Strengthening of the chassis in the interest of safety is recommended. Lightening or reducing the chassis strength is prohibited, and competitors should bear in mind that if the removal of any material results in weakening the structural integrity the chassis, then the Clerk of the Course or Eligibility Scrutineer (at their own discretion) will be fully authorised to exclude the vehicle from competing.

Tow hooks are to be either wire or fabric looped and be capable of pulling the vehicle weight
In addition to NCR Ch.12 App.13 Art.1.3 it is recommended that vehicles should where possible be equipped with two front and two rear towing eyes positioned equally either side of the longitudinal centreline. They must be clearly visible, marked with an arrow and the word "tow" and the wire painted in yellow, red or orange to contrast with the vehicle colour.

The towing eyes must be made of at least 6mm diameter steel wire rope with a 6x19 wire core, each which must have a breaking strain of at least 2 tons. Each towing eye must allow the passage of a cylinder with a diameter of 60 mm, situated 25mm forward of the adjacent bodywork - 100 mm above and below this hole must retain clearance to enable the recovery crews to attach straps and shackles.

The towing eye must be fixed to a structural part of the chassis with a minimum of M12 fixings, the inner part must be flexible in order for the towing eye to be retracted inside the bodywork profile. A "pull-cord" must be attached to the towing eye to enable the marshals to access the wire loop. The end attached to the chassis may be either 'thimble' or 'open loop' style.

5.6 BODYWORK

All Classes (except BMWcup & M2 Cup – see Appendix 1 & 2):

All panels other than specified below – must remain as per the manufacturer's original material, construction, dimensions, basic shape and thickness on all exterior surfaces above and below the hub line.

M1 & M2 & Class 6:

Lightweight: bonnet, boot, tailgate, wings, bumpers and doors are permitted.
Roof: Carbon/composite permitted.





Class 6:

~~Lightweight boot, bonnet, bumpers, doors and wings permitted.
Roof: Original or OEM panel.~~

Class 4:

Lightweight boot, bonnet, bumpers and wings permitted.
Roof: Original or OEM panel.

Aero and body kits: Vehicles may use original, or replica BMW factory supplied body kits such as those fitted to "works" or "factory produced" race cars. Any other body kits must receive the organiser's written approval before purchasing or fitting any body kit.

Splitters, where fitted, must be no wider than the vehicle front profile and extend no more than **100mm** from the vertical plane of the standard front valance/bumper.

Front under trays - permitted but not extend further back than the engine cross member.

Bonnet Ventilation - The use of vents/grills in the sides of the bonnets for heat dispersion is allowed subject to the regulations on silhouette.

Class M1:

A rear diffuser is permitted but must not protrude beyond the external bodyline or attach to rear panel. Underside body shell contours (with the exception of the section between the rear chassis legs that houses the spare wheel and battery tray) to remain as production shell, no aero devices are permitted on the underside of the body other than fitting standard BMW manufactured items.

The diffuser may reach/not go beyond the original location of the rear of the spare wheel/space saver position on the boot floor.

Rear bumper panel can be removed.

Rear spoilers are free but must not extend beyond the width and roofline of the vehicle.

Class M2, 6 & 4:

Vehicles may be fitted with spoilers originally supplied by BMW for that model vehicle or a direct copy approved by the club's eligibility scrutineer and coordinator.

A list of acceptable spoilers is listed below.

If the cage has a diagonal or cross then a carbon roof is allowed in Class M2 ONLY.

A rear diffuser is permitted but must not protrude externally beyond the bodyline or begin beyond the original location of the rear of the spare wheel/space saver position on the boot floor.

Diffusers may not attach to the rear panel.

Underside body shell contours (with the exception of the section between the rear chassis legs that houses the spare wheel and battery tray) must remain as production shell, no additional aero devices are permitted on the underside of the body other than fitting of standard BMW manufactured items.

Rear bumper panel can be removed.

M2:

Rear spoiler - Max size mm (1420x340x350) excluding end plates.

Class 6 and 4:

Rear Spoiler BMW OEM or copy, BMW GT, DTM, M3 Cup, STW, position not modified or extended.





M2, Class 6 and 4:

The spoilers must not extend beyond the maximum width of the vehicle or above the maximum height of the roof.

BMWcup Class:

Refer to specific regulations (Appendix 1) - all steel panels – no spoilers or lightweight modified panels
MANDATORY parts MUST be used in the BMWcup class. (see Appendix 1)

M2 Cup Class:

Refer to specific regulations (Appendix 2)

MODIFICATIONS PERMITTED

1) **General:**

- a) Windows: Clear Perspex windows are allowed in the side windows and rear windows only and must be installed to the Organisers satisfaction. Windows Glass (inc front windows) M1 M2, Class 6 and Class 4 – conform to NCR Ch.7 App.2 Art.22.7

2) **Interior:**

- a) Driver's seat must be replaced with a competition seat fitted in accordance with NCR Ch.7 App.7 Art.2
- b) All passenger seats, floor coverings, roof lining, sound deadening materials, radio/stereo units, speakers and associated wiring may be removed.
- c) Redundant interior metal bracketry such as rear seat mountings may be removed, however competitors should bear in mind that if the removal of any material results in weakening the structural integrity of any panel, then the Clerk of the Course (at their own discretion) will be fully authorised to exclude the vehicle from competing.
- d) Spare wheel & associated parts, and all tools must be removed.
- e) Additional instruments are permitted, but the original dash binnacle (for M1 & M2, this can be replaced with a lightweight dashboard of a similar profile) and instrument cluster, must be retained and fitted in their original positions.
- f) The dashboard must be retained and securely fitted in its original position, however localised trimming is permitted to allow roll cage fitment and the addition of aftermarket switchgear or pull cables. The removal of the glovebox, lid and hinges is permitted.
- g) Subject to NCR Ch.7 App.2 Art.11 the steering wheel may be changed. Air bags must be disabled if the standard steering wheel is used. Glass sunroofs must be removed or replaced as per NCR Ch.12 App.13 Art.11.8.

3) **Exterior:**

- a) Other than the modifications detailed in section 5.6, vehicles must use standard or standard pattern exterior parts. Competitors other than those in BMWcup are allowed to fit a cold feed through the full beam unit – however the other lights must still operate

4) **Silhouette:**

- a) The standard silhouette in all elevations must not be altered with the exceptions of the permitted modifications listed in 5.6

5) **Ground Clearance:**

- a) No vehicles are permitted to have skirts or intermediary devices bridging the gap between the underside of the chassis or bodywork and the ground and must retain a minimum ground clearance of 60mm.

MODIFICATIONS PROHIBITED

- a) **General:** No alterations other than specified above permitted.
- b) **Interior:** No alterations other than specified above are permitted.
- c) **Exterior:** No alterations other than specified above are permitted.
- d) **Silhouette:** As above
- e) **Ground Clearance:** As above





5.7 ENGINE

To qualify the basic engine needs to be as fitted and supplied to production BMW models available through the dealer network and produced in volume (1000 units or more within the EU.) Forced induction engines are only permitted in class M1

1 MODIFICATIONS PERMITTED

M1:

Modifications to head and block are free but must be based on original standard parts. Crankshaft, connecting rods, pistons, valves, camshafts and manifolds are all free. Engine capacity may not be increased by more than 2%. Dry sump lubrication is allowed.

M2:

Modifications to head and block are allowed but must be based on original standard parts. Crankshaft, connecting rods, pistons and valves should remain BMW dealer original equipment items. Reprofiled and aftermarket CAMs are permitted. Engine capacity may not be increased by more than 2%. Dry sump lubrication is not allowed.

Class 6 & Class 4:

Modifications to head and block are allowed but must be based on original standard parts. Crankshaft, connecting rods, pistons, valves, and manifolds and camshafts should remain unmodified BMW dealer original equipment items. Engine capacity may not be increased by more than 2%. Dry sump lubrication is not allowed.

2 MODIFICATIONS PROHIBITED

All Classes: The engine location, its mounting position and locating points, must remain as manufacturer specified as originally supplied by the manufacturer for the particular model entered. For some custom fitments the owner should consult the coordinator prior to making any modifications.

3 OIL/WATER COOLING

The fitting of an oil cooler and modification of the cooling system is permitted. The location and size is free.

4 INDUCTION

Turbo Petrol engines and Turbo Diesel engines will only be permitted to race in M1 & M2 providing they meet the criteria for the maximum power to weight ratio for a turbo engine as per the tables in section X ~~Retaining factory charger and function specification.~~

Aftermarket or CSL air boxes are ONLY permitted in M1 (all models) ~~and in M2 when fitted to an S14 engine~~, they are prohibited within M2, Class 6, Cup Class and Class 4

Aftermarket & Standard Independent throttle bodies are allowed in M1 & M2

Standard Independent throttle bodies are not permitted in BMWcup, Class 6 and Class 4 unless fitted to an S14 engine. For forced induction vehicles only original throttle bodies correct for the type of engine used are permitted.

Induction kits and aftermarket air filters (provided the Air Mass/Flow Meter is retained) are allowed in all classes.

A cold air feed is permitted via a single full beam light fitting kit– all other lights must remain operational.

5 EXHAUST SYTEMS

Exhaust systems must comply with the silencing regulation as laid down in the current version of NCR.





6 IGNITION SYSTEMS

M1 and M2: The ignition system is free.

Class 6, M2 Cup, BMWcup & Class 4: Vehicles must retain the standard BMW ignition system,

All Classes: For vehicles fitted with aftermarket ECU's only one map is permitted. If more than one map is present within the ECU the penalty will be exclusion, ECU's must remain "unlocked" to allow compliance checks to be made. For vehicles utilising OEM ECU's capable of running multiple maps such as the standard E46 M3 ECU Sport Mode, if more than one map is present the vehicle will be tested on all maps and the highest power output will be used to determine compliance with the regulations. Standalone and "piggy back" ECU's (including JB4 models) with the potential for Bluetooth communication are not permitted.

7 FUEL DELIVERY SYSTEMS

All Classes (except BMWcup & M2 Cup – see Appendix 1 & 2): Fuel pumps, fuel tank, swirl pot and lines are free.

5.8 SUSPENSION

All Classes (except M1):

Vehicles must use the standard suspension pickup points on the body/chassis of the vehicle and the suspension must use the original design/type i.e. McPherson Strut that was applicable to the original vehicle model and design. Suspension components are interchangeable from one model to another as long as the chassis pick-up points remain as original.

If active suspension was a standard road car option by BMW. If the same original system is fitted to your vehicle – the standard and original system it will be allowed. You will NOT be allowed to race with aftermarket active or traction control suspension – ask if not clear. Four-wheel drive systems whether original standard BMW or otherwise is not allowed

M1:

Vehicles must use the standard suspension pickup points on the body/chassis of the vehicle, except for the lower arm pick up point on the rear subframe (this is free), and the suspension must use the original design/type i.e. McPherson Strut that was applicable to the original vehicle model and design. Suspension components are interchangeable from one model to another as long as the chassis pick-up points remain as original.

If active suspension was a standard road car option by BMW. If the same original system is fitted to your vehicle – the standard and original system it will be allowed. You will NOT be allowed to race with aftermarket active or traction control suspension – ask if not clear. Four-wheel drive systems whether original standard BMW or otherwise is not allowed

Class 4 & BMWcup:

Only One-way adjustable dampers are allowed in Class 4 and BMWcup (bump and rebound combined.) Remote canisters are not permitted.

Class 6:

Two-way adjustable dampers are allowed.

Class M2:

Up to Three-Way adjustable dampers (bump, rebound and high speed rebound) are permitted.

M1: Up to Four-Way adjustable dampers (bump, rebound, high speed bump and high-speed rebound) are permitted.

M2 Cup: see appendix 2



1 MODIFICATIONS PERMITTED

All classes: Modification to the suspension is subject to the following conditions: The spring and damper configuration and all of the original mounting points must be retained and used in the operation of the suspension for that particular model except that coil over dampers may be used on the rear. The replacement of bushes by adjustable spherical bearings is only permitted on the following: The top mounts of front dampers, the top and bottom of the rear dampers and anti-roll bars.

All other bushes and bearings must either be as originally supplied; replaced by spherical bearings inside the original mounting; BMW supplied Group N alternatives or with the rubber replaced by nylon/polyurethane or nylatron type material.

Aftermarket links and arms are allowed as long as they follow the design and style as original vehicle and operate in the same way.

2 MODIFICATIONS PROHIBITED

None other than listed in 5.8 & 5.8.1

Wheelbase/track:

Wheelbase must remain as per manufacturer's original specification for that particular model.

5.9 TRANSMISSIONS

BMW dealer mainstream supplied gearboxes may be swapped from model to model. Mounting and Location points must be used as intended by the manufacturer. Internal ratios and gears must remain original for the gearbox used.

Aftermarket gear kits and sequential boxes are not permitted other than Invitational entries. SMG transmissions where original fitted to that model vehicle will be allowed – all associated parts to remain as original. [M2 Cup must be to the regulations in Appendix 2.](#)

1 PERMITTED MODIFICATIONS

None

2 PROHIBITED MODIFICATIONS

The fitting of sequential gearboxes to vehicles in which they were not originally available.

The use of non-BMW parts and/or ratios, which did not appear in the production version of the gearbox in question will not be allowed within any class.

Re-location of the gearbox or final drive from its original position as specified by the manufacturer for that particular model.

The fitting or use of traction control and/or launch control systems are prohibited unless fitted as standard on the original vehicle and remains the standard software – in any class other than M1 Fitting of aftermarket active or intelligent suspension systems is not allowed.

Four-wheel drive systems will not be allowed

3. TRANSMISSIONS & DRIVE RATIOS:

Final drive ratios and differential units are free with exception of BMWcup class vehicles. Only casings and ratios found in original production BMW models can be used in classes M1, M2, Class 6, BMWcup and Class 4.





5.10 ELECTRICS

- 1) **Exterior Lighting:**
Must be as per standard fitment and to EC requirements and be fully operational. Front lights/lamps must be taped to or covered with a transparent protective plastic / vinyl film. (exception is using a single full beam for cold feed in Class's M1 M2 6 and 4)
- 2) **Rear Warning Light:**
Vehicles must be fitted with a manually switchable rearward facing red warning light which must be fully compliant with the NCR Ch.7 App.5 Art.6
- 3) **Batteries:** No restrictions on type or location subject to NCR's. A battery and electric starter motor must be fitted and be capable of repetitive starts. No external (slave) batteries may be used.
- 4) **Generators:**
A fully working standard alternator and standard pulley must be fitted and electrically connected so that the standard battery charging function is providing a charge to the onboard battery.
- 5) **Wiring:**
The vehicle wiring loom may be modified.

5.11 BRAKES

Other than BMWcup & M2 Cup class - brake regulations are free in terms of disc, calliper and pad sizes

BMWcup refer to Appendix 1 – as should remain standard in terms of function and size and type of callipers, discs and control pads

M2 Cup refer to Appendix 2

All braking components are competitor's choice (M1, M2, 6 & 4) inc. braided hoses. The removal of the back plates is permitted - replacement with cooling ducts is recommended.

5.12 WHEELS / STEERING

- 1) **Permitted Options:**
An original, BMW steering rack must be used. The steering lock should be rendered inoperative, unless the vehicle is driven to the circuit on the highway.
- 2) **Prohibited Options:**
No machining or other modification of the road wheels are permitted. High ratio steering racks may be fitted with in a BMW manufactured casing. Power steering pumps and equipment may be removed. Electric power steering is allowed
- 3) **Construction & Materials:** Magnesium wheels are not permitted.
- 4) **Dimensions:**
Wheel diameter:
Class M1 M2 19", 18", 17", 16" & 15" (~~plus 19" for Uniroyal's but only if 19" were available as new on the model in the UK~~)
Class 6 18", 17", 16" & 15"
M2 Cup 18"
BMW Cup 17"
Class 4 17", 16", 15"
Invitation up to 19"
- 5) **Wheel Spacers:**





Wheel spacers are permitted provided that the vehicle track remains within the limits permitted in rule 5.8.3 and they are of the 'hub-centric' type and of the correct p.c.d. Where spacers are used, they must be fitted in equal pairs across the axle. Universal wheel spacers are not permitted, and competitors should ensure that wheel bolts are of sufficient length to adequately secure each wheel. Wheel hubs may be fitted with conversion studs to accept wheel nuts.

5.13 TYRES

TYRE FITMENT options and sizes available through the organisers, or approved manufacturer suppliers

SPECIFICATIONS - Treaded tyres – as per current NCR Ch.8 App.4 for lists of 1A, 1B and 1C tyres (refer to BMWCCR manufacturer for additional detail)

Invitation and guest vehicles have the full choice of tyres within NCR Ch.8 App.4 1B, 1C lists for one Event

Permitted Tyres for Class M1, M2, BMWcup, 6 & 4 are as follows (note: 19" tyres are only permitted in class M1 & M2)

Pirelli	Trofeo R	15"- 18" <u>19"</u>	1B
MRF	ZTR (code 25 or 48 only)	17"- 18" <u>19"</u>	1C
Nankang	AR1 & CR-S	15"- 18" <u>19"</u>	1B
Uniroyal	Rainsport (any)	15"-19"	1B
Davanti	Protura	15"-18"	1B

The maximum permitted tyre width in each class is as follows:

Class M1	265mm
Class M2	255mm
Class 6	245mm
Class 4	235mm
BMWcup	225mm
<u>M2 Cup</u>	<u>265mm</u>

Tyres used during qualifying, or the start of a race should not be worn below 1.6mm. If deemed out of spec they will need to be changed prior to entering the track.

Whilst the BMW Car Club allows purchase of the listed tyres from ANY supplier, we recommend drivers and teams can purchase direct from the organisers or via the approved supply chain – the options are then to have them fitted at a race Event or delivered and fitted to a manufacturer outlet without extra costs.

The outlet locations, approved suppliers and booking forms are available via the website or through the co-ordinators

5.14 VEHICLE WEIGHT

1) Minimum weights apply to each class including driver post practice or race. Random checks will be carried out during the season and no vehicle/driver combination shall be below this minimum weight. All minimum weights are including driver and race overalls, helmet etc.

M1	1080kg
M2	900kg
6	1000kg
BMWcup	1250kg
4	900kg
M2 Cup	<u>see Appendix 2</u>
Inv	1250kg

2) The minimum vehicle weight for individual vehicles will be calculated from the declared or tested power of the vehicle. This figure must be displayed as a graphic on the side window of each vehicle. The minimum weight includes the driver and may be checked post practice or race. Random checks will be carried out





during the season and no vehicle/driver combination shall be below this minimum weight. All minimum weights are including driver and race overalls, helmet etc.

5.15 FUEL TANK / FUEL

- 1) **Types:** Fuel tanks are free (except BMWcup & M2 Cup – see Appendix 1 & 2)
- 2) **Locations:** If present, the standard fuel tank must be in standard position. The location of aftermarket tanks is free subject to Event NCR safety criteria.
- 3) **Fuel:** Only petrol as defined in the current NCR Ch.8 App.1 Art 1.7a. Fuel which exceeds the stated RON (max) levels in NCR Ch.8 App.1 Art.1.7a is prohibited even if it is sold/promoted as being legal for UK Competition and/or obtainable from 'roadside' pumps. The use of additives by competitors which boost the octane rating (RON) in any petrol is prohibited. At the end of practice and the race at least 3 litres of petrol from the tank of the competing vehicle must be available to the scrutineers for analysis. Compliance with minimum weight for the vehicle will be taken before the petrol is removed
- 4) **Fuel Tank/Fuel:** drivers should be able to supply a sample from between the pump and engine within Parc Ferme following request. (The club can provide sample valves if needed).

5.16 SILENCING

All vehicles must comply with the relevant maximum noise limits set out in NCR Ch.7 App.13 Chart 1 Maximum noise limits.

5.17 NUMBERS AND SERIES/CHAMPIONSHIP DECALS

- 1) Race numbers – to be fitted as per the NCR.
- 2) Organising Club and BMWCC GB on each side of the vehicle as instructed
- 3) All Sponsors' and partner decals to be fitted as instructed by the Club Co-ordinator
- 4) Class identifier alongside the competition number
- 5) Vehicle weight and declared power figure to be displayed in rear quarter window
- 6) Driver's name fitted near to side race number
- 7) Front Sun strips will be supplied by organisers and must be fitted in accordance with NCR Ch.12 App.4 Art.5.
- 8) Decals will be supplied by the Title sponsor, and/or any other sponsor and/or the Organisers.

6 PADDOCK DISCIPLINE

You are required to park competition vehicles together in the paddock. Please follow the instructions on the final instructions regarding paddock layout. If you fail to do so, you will be asked to move, either by another official race coordinator or our club representative. You are obliged to follow instructions on this procedure. Failure to readily comply, could lead to the suspension of your membership of the club, which would in turn render you ineligible to race. Please assist us by ensuring that this does not occur.

The BMW Car Club will work with all organising clubs and partners to liaise with the circuits to ensure that the day(s) racing is as enjoyable and stress free as possible. In that aim we also request that all competitors and their friends that come to support them respect all the other parties involved or taking part at the Events. If there are instances where people bring the club into disrepute, or any altercation is reported it will be investigated, and penalties will be levied that could result in exclusion or removal of any person that is deemed to not be respecting the club rules and other visitors to the Event in question. This will be a decision between the circuit, club organisers and Clerk of the Course as appropriate.

7 TECHNICAL CHECKS

The eligibility scrutineer/organisers reserve the right to inspect any vehicle at any time and this will be carried out in the scrutineering bay/paddock or team garage. They also reserve the right within the rules of the NCR to strip or seal any part or parts of a vehicle.



The competitor will bear costs of such an inspection. If the vehicle is found to be outside the regulations for the class entered it could lead to exclusion from the results of that event and the loss of reward points scored to that date, the eligibility scrutineer/organisers reserve the right to escalate any infringement further by invoking the provisions of NCR Ch.2 App.8 Art.2

The eligibility Scrutineer/organisers reserve the right at any time to subject a vehicle to an official test to check engine power. The same right will exist to measure the weight of the vehicle. Failure to comply at the time of request will render the competitor to loss of their 2 highest points scoring rounds to the date of the refusal.

It is the competitor's responsibility to ensure that the vehicle entered complies with the regulations, even if they are not the builder or assembler of the vehicle. Any vehicle found to be in contravention of the regulations will render the competitor and vehicle to be excluded.

On occasion the championship organisers may nominate people to work alongside and advise the MOTORSPORT UK Eligibility Scrutineer at the Events. They are available for assistance with interpretation of the regulations and have the absolute right to inspect any competing vehicle. Please assist them with their duties. Any refusal will be deemed to be a breach of these regulations and may result in disqualification.

8 CONTACTS

RACE ORGANISING CLUB AND CONTACTS

Promotor	Neil McDonald
Club	BMW Car Club GB
Telephone	07767 688233
Email	neil@bmwcarclubgb.co.uk
Eligibility Scrutineer	Simon Dockray
Deputy Eligibility Scrutineer:	Bob Blackmore
750MC Contact	Giles Groombridge
Telephone	01332 814548
Email	giles@750mc.co.uk

Commercial Undertakings:

All drivers are required to be members of the BMW Car Club GB and the 750 Motor Club.

Trade Support Vehicle Decals - Any competitor who is proposing to carry vehicle sponsor advertising which may be deemed to be in conflict with the main Sponsor/s must first seek the approval of the Championship Co-ordinator prior to the appearance of the vehicle at its first Event of the season. Any decision that is made by the co-ordinator in this respect shall be at his/her discretion and shall be final.

Should a competitor bring BMW Car Club Racing into disrepute, their membership of the club and their entry for racing will be suspended.

9 MANDATORY SPONSOR DECALS

1) Positions:

Race numbers must be in accordance with NCR Ch.7 App.10 and Ch.12 App.4 Art.5. 750 Motor Club decals must be affixed prominently. Additionally, vehicles must have the following:

- a) Names: Drivers proper or known name (first or surname) Max 50mm high under the race number.
- b) The "Power figure" and given minimum weight – in white at least 20mm in height
- c) Class identification – M1, M2, 6 BMWcup and 4 in a contrasting dayglo orange and 100mm in height
- d) Vehicles will also be required to carry Championship sponsor's decals (where applicable) which must be affixed in or near the positions detailed on any diagram supplied with those decals. 750 Motor Club



and Championship Sponsor's decals must take preference to any other decals. Failure to comply will render the vehicle and driver ineligible to race.

2) **Suppliers:**

Sponsors and Club decals will be available at the first Championship race in which the vehicle is entered.

10 NOMINATED ROLLING ROADS

**BMWCCR – BMW Car Club Racing Championship
Designated Rolling Roads 2024**

Beds/Buck/Herts	Telephone
Revivals Garage Lodge Road Thriplow, Royston Herts SG8 7RN	Tel: 01763208043
Marlin Motor Engineers Unit 4-5 Wellington Place Bletchley Milton Keynes Buckinghamshire MK3 5NA	Tel: 01908 366256
<u>Automac Ltd</u> <u>Unit 1b,</u> <u>Sand Road Industrial Estate</u> <u>Great Gransden, SG19 3AH</u>	<u>Tel: 01767 679000</u>
Eastern	
Alive Tuning Unit 1 & 2 Meridien Centre Belvoir Way Fairfield Industrial Est. Louth Lincolnshire LN11 0LQ	Tel: 01472 812900
Midlands	
TI Motorsport Tegiwa House Sutherland Road Stoke ST3 1HZ	Tel: 01782 950315
Car Trac Dyno Main Road Pontesbury Shrewsbury	Tel: 01743 790554
Mallory Performance Unit 1-6 Mallory Park Race Circuit Kirby Mallory	Tel: 0116 216 5112
West	
RE Performance Scuderia House, Newcombe Drive, Swindon SN2 1EG	Tel: 01793 278069



North	
Sheffield Rolling Road Unit 4 Dannemora Dr Sheffield S9 5DF	Tel: 0114 332 0154
Moorfield German Motors Unit B Moorfield Road Estate Yeadon Leeds	Tel: 01132 508333
South East	
KAP Ross Way Folkstone Kent	Tel: 01303 228200
CCK Historic Rosehill Farm Burnt Oak Road High Hurstwood Uckfield E Sussex	Tel: 01825 733060
Harding Auto Services Robin Hood Works Robin Hood Rd Knaphill S London	Tel: 01483 487626
South West	
Collins Of Probus Unit 2-3 Tresillian Business Park Truro	Tel: 01872 520654
Powers Auto Ltd Northway Trading Est Northway Lane Tewkesbury	Tel:01684 296675
Tipton Garage Tipton St John Near Sidmouth Devon	Tel: 01404 812091
Scotland	
Raceworx Performance Centre Unit 2 Block 1 Hunting Park, Livingston EH54 5QS	Tel: 07483 161958

Centre for additional technical checks **ONLY** (via coordinators referrals)

Chip Wizards
Unit 3 Victoria Way, Rawtenstall,
Lancashire BB47NY
wayne@chipwizards.co.uk



Automac Ltd
 Unit 1b,
 Sand Road Industrial Estate
 Great Gransden, SG19 3AH

Power & Weight Tables: Naturally Aspirated Vehicles

M1		M2		Class 6		Class 4	
BHP*	KG*	BHP	KG	BHP	KG	BHP	KG
450	1462	285	1440	285	1590	220	1481
440	1437	280	1413	280	1560	215	1444
430	1412	275	1386	275	1530	210	1407
420	1387	270	1359	270	1500	205	1370
410	1362	265	1332	265	1470	200	1286
400	1337	260	1304	260	1440	195	1272
390	1312	255	1277	255	1410	190	1259
380	1287	250	1250	250	1380	185	1222
370	1250	245	1223	245	1350	180	1185
364	1228	240	1196	240	1320	175	1169
354	1194	235	1168	235	1290	170	1154
342	1150	230	1141	230	1260	165	1115
331	1110	225	1114	225	1230	160	1077
322	1080	220	1087	220	1230	155	1038
		215	1060	215	1170	150	1000
		210	1033	210	1140	145	962
		205	1005	205	1110	140	923
		200	978	200	1080	135	905
		195	951	195	1050		
		190	924	190	1020		
Min	1080	Min	900	Min	1000	Min	900

BMWcup – to remain Minimum Weight 1250kg with standard ECU with EWS removed so the organisers can swap to resolve any dispute or concern.

Power & Weight Tables: Forced Induction Vehicles



<u>M1</u>		<u>M2</u>	
<u>BHP*</u>	<u>KG*</u>	<u>BHP</u>	<u>KG</u>
<u>450</u>	<u>1484</u>	<u>285</u>	<u>1456</u>
<u>440</u>	<u>1459</u>	<u>280</u>	<u>1429</u>
<u>430</u>	<u>1434</u>	<u>275</u>	<u>1401</u>
<u>420</u>	<u>1409</u>	<u>270</u>	<u>1374</u>
<u>410</u>	<u>1384</u>	<u>265</u>	<u>1346</u>
<u>400</u>	<u>1359</u>	<u>260</u>	<u>1319</u>
<u>390</u>	<u>1334</u>	<u>255</u>	<u>1291</u>
<u>380</u>	<u>1309</u>	<u>250</u>	<u>1264</u>
<u>370</u>	<u>1273</u>	<u>245</u>	<u>1236</u>
<u>364</u>	<u>1251</u>	<u>240</u>	<u>1209</u>
<u>354</u>	<u>1215</u>	<u>235</u>	<u>1181</u>
<u>342</u>	<u>1171</u>	<u>230</u>	<u>1154</u>
<u>331</u>	<u>1131</u>	<u>225</u>	<u>1126</u>
<u>322</u>	<u>1098</u>	<u>220</u>	<u>1099</u>
		<u>215</u>	<u>1071</u>
		<u>210</u>	<u>1044</u>
		<u>205</u>	<u>1016</u>
		<u>200</u>	<u>989</u>
		<u>195</u>	<u>962</u>
		<u>190</u>	<u>934</u>
<u>Min</u>	<u>1080</u>	<u>Min</u>	<u>900</u>

APPENDIX 1: BMW CUP**1) Logbook**

Upon registration a logbook is to be completed to confirm vehicle specification to include chassis/VIN/Engine details to ensure conformity to the BMWcup and BMWCCR regulations

2) Bodywork

External body body panels and silhouette as per original factory E46 325 (all body types)
All Steel panels – can be trimmed/skinned – rear seat and seatbelt mounts can be removed



OEM Bumpers, front under tray, bulkheads to remain standard, dealer supplied rear spoiler is allowed, no front splitters

a) **Rear End**

Standard pick up points. Rear beam to be Standard. Superpro bushes can be fitted Shafts, Hubs and trailing arms to remain standard

b) **Front end** - Beam to remain standard, Lower arms to be as original other than Superpro bushes

c) **Windows** - Polycarb windows allowed (side/rear), if heater removed – a heated screen to be fitted

3) Engine

Fitted as standard to the E46 325 – all specification to remain standard)

M54B25 2,494 cc (152 cu in) engine with an 84 mm (3.3 in) bore and 75 mm (3.0 in) stroke. Output 141 kW (189 hp) at 6000 rpm and 245 NM (181 lb·ft) torque at 3500 rpm.

To avoid avoidable costs all competing engines can be purchased for £1000+vat (STC)

a) **Induction** OEM up to and including Air Mass meter (AMM) plus standard or approved K&N filter

4) Fuel

Standard tank, pump and pickup and fuel. Twin pumps or M3 baffle can be fitted
No swirl pot or external lift pumps or additional pressure devices

5) Suspension

Standard position an operation design

Dampers - PSS9/10 Bilstein coilover kit. Top mounts - Standard or K-Mac as per parts list

Eibach Springs - Front - Approved Race springs, Rear - Approved Tri rate coil spring Antiroll bars remain standard diameters F-27mm R-19mm, standard ARB links Front lower arm bushes can be offset with bushes or kept standard

6) Steering

Unmodified purple tag steering rack, with standard PAS

7) Transmission

Original Getrag 5 speed manual as fitted to E46 325 –The standard flywheel and clutch can be used or the solid BMWcup version mated with the E36 M3 Evo clutch.

a) **Differential** - Standard unit as fitted to E46 325ti – smooth case - open (non LSD) 3.23 CW

b) **Propshaft** - Original as fitted to E46 325

8) Electrical

Standard MS43 ECU – will be swappable an retain standard map

No – piggy back control units for engine or traction aids - disqualification could result

9) Safety

approved 6 point bolt in cage by custom cages – other as per BMWCCR regs

10) Brakes

Standard ATE calipers and disc size – can upgrade hoses and brake fluid

Front – discs vented 300mm diameter / 52mm height/22mm thickness

Rear size discs vented 294mm diameter / 60 mm height/19mm thickness

Approved Discs – Front GD932 or USR932 Rears – GD933 or USR933 Approved Pads - DP51211NDX and DP51289NDX

11) Wheels and tyres

Wheels – 17" Diameter, Maximum width 8.5" Tyres – see 5.13

12) Weights

Minimum weight 1250kg



13) Exhaust

Vortex/SuperSprint/Standard OE exhausts vehicles must run with the lambdas as originally fitted exhaust manifold to remain standard – with catalysts intact and operational

14) Costs

BMWcup is designed to be cost effective entry to racing and discounts are available

15) Driver Standards

Refer to driving standards within BMWCCR regulations.

16) Contacts:

Neil McDonald 07767688233 neil@bmwcarclubgb.co.uk

APPENDIX 2: BMW M2 CUP

1. Technical regulations of the M2 Cup.

1.1 Overview of the groups/classes

The only vehicles eligible for competition in the BMW M2 Cup Class are BMW M2 Racing vehicles that conform to the technical requirements of these Technical Regulations.

The series production BMW M2 Racing model serves as a basis for the vehicle.

The series organiser reserves the right to approve and/or operate one or more replacement vehicles in exceptional circumstances.

1.2 Basis for the Technical Regulations

- Current Motorsport UK NCRs
- These Technical Regulations
- G87 M2Racing Technical Customer Manual in the latest version (hereinafter also referred to as the "Manual")
- Electronic Parts Catalogue of BMW AG for the BMW M2 Racing (hereinafter also referred to as the "EPC")

By entering and participating in the respective event, participants confirm that they are aware of the aforementioned documents and that they accept and will comply with the associated rights and obligations.

1.3 General/preamble

Everything not explicitly permitted under these Technical Regulations is prohibited. Permitted modifications must not result in any unauthorised modifications or breaches of the Technical Regulations.

The aim and purpose of these Technical Regulations is to allow every participant to be competitive in their class without requiring investment to modify or develop the vehicle.

As a rule, the EPC of the BMW M2 Racing defines the competition vehicle. Deviations from this definition must be approved under these Technical Regulations or they are deemed to be inadmissible.

1.4 Driver equipment

Refer to current Motorsport UK NCR's.

1.5 General regulations, permitted modifications and installations





The BMW M2 Racing must comply with these Technical Regulations at all times during an event.

It is the responsibility of the participants/entrants to ensure that the vehicle is only operated if it is in perfect technical condition and complies with the safety regulations of Motorsport UK at all times.

The only work that is permitted on the vehicle is work that constitutes regular servicing or the replacement of worn parts or parts with accident damage.

Modifications and installations may only be made within the framework defined below. Any part worn through use or damaged due to an accident may only be replaced by an original part identical to the worn or damaged one.

Standard mountings such as nuts, bolts, washers, spring washers, wave washers and splint pins may only be replaced by standard parts corresponding to the original form. It must be ensured that the correct thread types, sizes and pitches are used (for example M8 x 1.25).

The entrant/driver/owner is hereby notified that, in events that have a separate Cup class especially for the BMW M2 Racing, the BMW M2 Racing (condition as delivered) is only eligible for competition in said Cup class. Should the event organiser not provide a separate Cup class especially for the BMW M2 Racing, it is the responsibility of the event organiser to assign the vehicle to a suitable class and regulate its performance using balance of performance measures. A waiver allowing participation in another class may only be issued by BMW M Customer Racing and applied for from the respective event organiser.



1.6 Minimum vehicle weight and ballast

The series organiser shall provide a weighbridge to measure the weight of the vehicle and the driver. It is deemed to be the 'official weighbridge'.

If a vehicle loses a part during free practice qualifying or a race, the weight of said part can be taken into consideration in terms of the vehicle weight. The Stewards, in consultation with Scrutineers, have discretion to determine whether and which lost parts are considered when weighing the vehicle.

Minimum weight:

The minimum vehicle weight is 1,560 kg (excluding the driver).

The weight of the vehicle must be equal to or higher than the minimum vehicle weight at all times during the event.

The following components are included in the minimum vehicle weight:

- MoTeC components (MoTeC C125 incl. MoTeC wiring loom, see 2.11) ¹
- Rear wing (see 2.10) ¹
- Ballast box plus cover, approx. 8.7 kg ¹
- Adjustable seat
- Shock absorbers
- Air jack system
- Front-axle reinforcement plate ²

¹ These components are mandatory; optional components may be offset with ballast if they are not installed.

² The reinforcement plate is compulsory if an air jack system is installed.

Ballast:

Ballast may be added to the vehicle to meet minimum weight requirements. As described in the EPC, this ballast must consist of fixed, uniform blocks and be attached to the floor of the passenger compartment using the ballast box base plate (part no. 8 324 128). The ballast box is to be sealed using the corresponding cover (part no. 8 428 060, transparent). The cover is to be sealed with a tamper-proof seal by the Scrutineers.

1.7 Displacement factor for turbocharged engines

n/a

1.8 Exhaust regulations

All vehicles must comply with the relevant maximum noise limits set out in NCR Ch.7 App.13

Vehicles must be equipped with a catalytic converter in accordance with Motorsport UK regulations.

1.9 Noise regulations

Should the optional muffler be required to comply with noise regulations, the muffler must be installed in accordance with installation requirements. Part numbers of all parts required to install the muffler: 7 884 220 / 2x 7 560 780 / 5 B6A 194.

For installation instructions, see the latest G87 M2Racing Technical Customer Manual.



1.11 Safety equipment

n/a

1.12 Fuel and, if applicable, control fuel

2. Special technical regulations

2.1 General

In additional to the Technical Regulations pursuant to Section 2 of these series specifications, the following special technical regulations also apply.

The vehicles must conform in full to the G87_M2Racing_Technical_Customer_Manual in the latest version as well as the current electronic parts catalogue, both of which describe the condition of the vehicle as delivered. Exceptions to this are modifications for safety reasons at the discretion of the series organisers, which are to be made to all vehicles.

Permitted modifications must not result in any unauthorised modifications or breaches of the Technical Regulations.

2.2 Engine

The engine is delivered by BMW as a sealed unit.

No modifications may be made to the engine or any engine parts.

Details of the engine seal and all sealed parts can be found in the latest version of the G87_M2Racing_Technical_Customer_Manual.

The Scrutineer must be informed in advance of the replacement of any sealed parts. The instructions of the Scrutineer are to be followed without exception. See Section 2.15.

2.3 Exhaust system

The exhaust system described in the EPC is to be used. The additional muffler, see Section 1.9, may be mandated or required. Only the parts listed in the EPC and in the latest version of the Manual may be used for the installation and operation of the exhaust.

2.4 Transmission

The gearbox and differential are delivered as non-sealed units.

No modifications may be made to the gearbox or differential.

2.5 Brakes

The entire braking system and all brake parts are to be procured exclusively through BMW.

The braking system is different to the standard version of the vehicle and is defined by the EPC. Driving aids (ABS, DSC and MDM) have been specially designed for use on the racetrack and may not be modified by the entrant/driver.



The vehicle must be run with the braking system and brake wear parts defined in the EPC.

Brake pads are free:

Brakes may only be cooled in the manner defined in the EPC.

2.6 Steering

The steering is defined by the EPC and must be installed in unmodified form together with all components.

2.7 Suspension

The suspension has been modified for racing and is defined by the EPC. It may not be modified as a rule, with the exception of the following adjustments, which may be made for set-up purposes:



- Adjusting the track on the tie rod.
- Adjusting the camber in the strut bearings on the front axle (see Manual) and the eccentric screws on the rear axle (see Manual).
- Adjusting the ride height on the shock absorber.
- Adjusting the roll stabilisers at the intended junction points.
- The roll stabiliser (front and rear axles) must NOT be disabled.

All parts used on the vehicle must be listed in the EPC and must be procured from BMW.

The compensation springs, assister springs and bump stops are therefore standardised parts. Modifications to parts, such as modifying the shock valves, are expressly forbidden.

All adjustments must be within the defined tolerances.

Shock absorbers:



<i>Shock absorbers</i>		
	<i>Front</i>	<i>Rear</i>
<i>Type</i>	HYDRAULIC / GAS	HYDRAULIC / GAS
<i>Make</i>	KW	KW
<i>Typical series number</i>	5B5B015 (LH) / 5B5B016 (RH)	5B5B018
<i>Gas tank</i>	NO	NO
<i>Volume of gas tank</i>	XX cm3	XX cm3
<i>Maximum open length</i>	480.3 mm DAMPER BOTTOM TO CONTACT SURFACE BODY	472.9 mm UNIBALL CENTER TO UNIBALL CENTER
<i>Minimum closed length</i>	381.8 mm DAMPER BOTTOM TO CONTACT SURFACE BODY	380.9 mm UNIBALL CENTER TO UNIBALL CENTER
		

(Figures: Shock absorber dimensions)



Compensation springs/springs:

Compensation Spring		
	<i>Front</i>	<i>Rear</i>
	<i>Main</i>	<i>Main</i>
Marque/Type of spring	COIL	COIL
Material	STEEL	STEEL
Diameter of wire	4.8 X 7.5 +/- 0.2 mm	4.0 X 7.0 +/- 0.2 mm
External diameter	76.5 + 1.0 mm	65.5 + 1.0 mm
Number of coils	4.25	4.5
Weight	216 +/- 10 g	156 +/- 10 g
Maximum free length	60 mm	60 mm
Stiffness	20 N/mm	20 N/mm
		MISSING PICTURES

Springs Set 1		
	<i>Front</i>	<i>Rear</i>
	<i>Main</i>	<i>Main</i>
Type of spring	COIL	COIL
Material	STEEL	STEEL
Diameter of wire	12.5 +/- 0.2 mm	12.5 +/- 0.2 mm
External diameter	87 +/- 2.0 mm	76.75 +/- 0.5 mm
Number of coils	5.3	6.9
Weight	1104 +/-10g	1264 +/- 10g
Maximum free length	140 mm	170 mm
Stiffness	160 N/mm	170 N/mm
	 Assy below for ref. only: 	Missing Pictures

(Figures: Compensation spring/spring dimensions)

2.8 Wheels (disc + rim) and tyres



Only approved rims as defined in the EPC may be used in the BMW M2 Cup Class (part no.: 5 B69 0D7).

These rims must be procured from BMW.

Tyres see BMWCCR Regulation 5.13

2.9 Bodywork and dimensions

a) External bodywork (incl. windows)

Window stickers are governed by the event organiser. Safety film is to be applied to the windows on the driver's side and passenger's side doors as described in the Manual. Adding openings to the windows for ventilation purposes is not permitted.

Closing or masking openings or panel gaps is generally not permitted. In the case of provisional repairs made during an event, openings or panel gaps in the direct vicinity of the damage may be masked if necessary to save time. The permissibility of repairs is at the discretion of the Scrutineer/Chief Scrutineer.

If unusually cold temperatures give rise to the need to close ventilation holes, this work is subject to the express approval of the Scrutineer/Chief Scrutineer.

Transparent, non-tinted tear-off strips may be affixed to the windscreen for protection. These tear-off strips must not be marked and must not contain any air bubbles obscuring the view of the driver.

b) Cockpit

No individual ventilation tubes are permitted.

A drinks system may be installed provided it is mounted to a fixed point and the bracket can withstand acceleration forces of up to 25 G. The decision as to whether the bracket is sufficient lies with the Scrutineer/Chief Scrutineer.

The pedal system may not be changed, with the exception of the application of grip tape.

The seat, seat console and seatbelts must conform to the EPC and may only be procured from BMW. The standard steering column adjustment is to be retained and must conform to the EPC at all times. All covers in the interior are to be used as described in the EPC.

If an entrant registers a driver who is unable to use the seat defined in the EPC without safety concerns due to their physical condition, the Scrutineer/Chief Scrutineer may grant approval for another seat with an associated console on the basis of a corresponding written application.

Evidence that the seat defined in the EPC cannot be used is to be provided to the competent Scrutineer/Chief Scrutineer by way of a seat fitting. Approval will be granted only if the Scrutineer/Chief Scrutineer identifies a safety risk.

Such an approval is driver-specific and therefore only applies when the respective driver is participating in an event. The alternative seat and console must conform to the current Motorsport UK NCRs and must be presented for inspection during scrutineering.

There are no specific formal requirements for such an application; however, the application must include the name and licence number of the driver as well as the manufacturer and serial number of the alternative seat and console.

c) Additional accessories

Accessories listed in the EPC may be installed and can be compensated for through the ballast specified in the foregoing Article 1.6 of these Technical Regulations.

2.10 Aerodynamic devices

Aerodynamic devices are the front splitter and the rear wing (optional).

The rear wing is not fitted to the vehicle as standard and MAY be installed, together with all specified components, in the manner described in the Manual and the EPC.

The position of the rear wing is defined as follows:

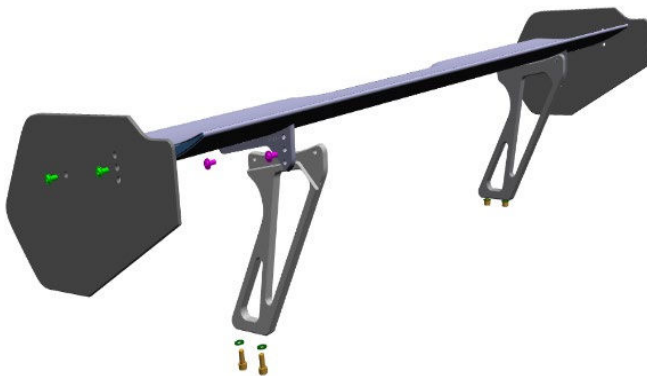
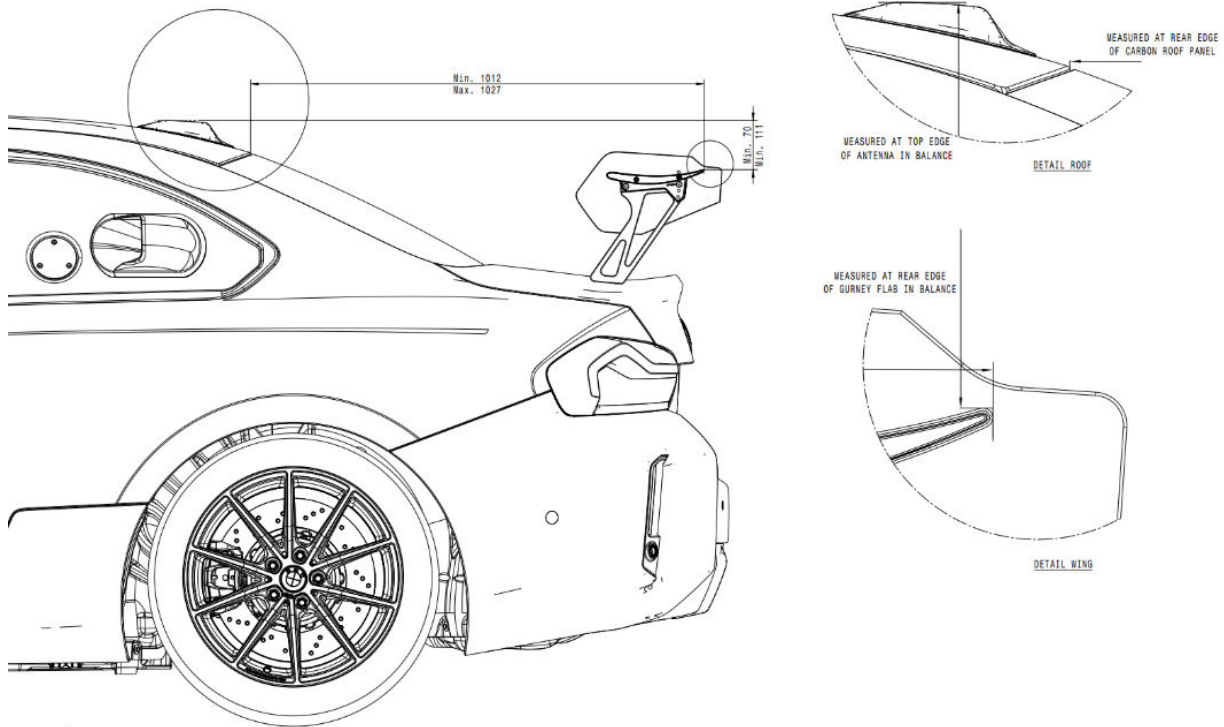



The entrant/participant is obliged to provide detailed information in writing on the operating fluids it uses (type, name, specification, manufacturer) at the request of the Scrutineer/Chief Scrutineer and/or BMW.

2.14 Data transfer

Refer to BMWCCR General Regulations and the current Motorsport UK NCRs

2.15 Repair, sealing and labelling of parts by BMW

Details of the engine seal and all sealed parts can be found in the latest version of the G87 M2Racing Technical Customer Manual.

The Scrutineer must be informed in advance of the replacement of the parts. The instructions of the Scrutineer are to be followed without exception.

2.16 Track width

- Front track width: max. 1,662 mm
- Rear track width: max. 1648 mm

Measurement instructions:

The vehicle is measured at the reference area. Reference is made to Article 1.6 (weighbridge) with regard to the reference area. Tyre pressures may be increased to the reference pressure (2.0 bar) for the measurement procedure.

On the axle that is being measured, a 90° angle is positioned on the ground directly beneath the centre of the axle and placed flush against the inner and outer sidewalls of each tyre. These four positions are marked on the ground.

The distance between the markings (outer to outer and inner to inner) is measured, added together and halved. The resulting value is the track width.

2.17 Ride height

Ride height is measured with an empty fuel tank and without a driver.

No part of the vehicle may be in contact with the ground when the tyres on one side of the vehicle are not inflated. This test is to be carried out on a level surface with a race-prepared vehicle and a driver on board.

The areas designated in the following figure are used as measurement points on the vehicle:



Basic Setup at vehicle delivery:

Front Ride Height*	
Left	Right
95 mm	95 mm

*) Refers to setup wheels.

Rear Ride Height*	
Left	Right
133 mm	133 mm

*) Refers to setup wheels with 2.0 bar tire pressure.

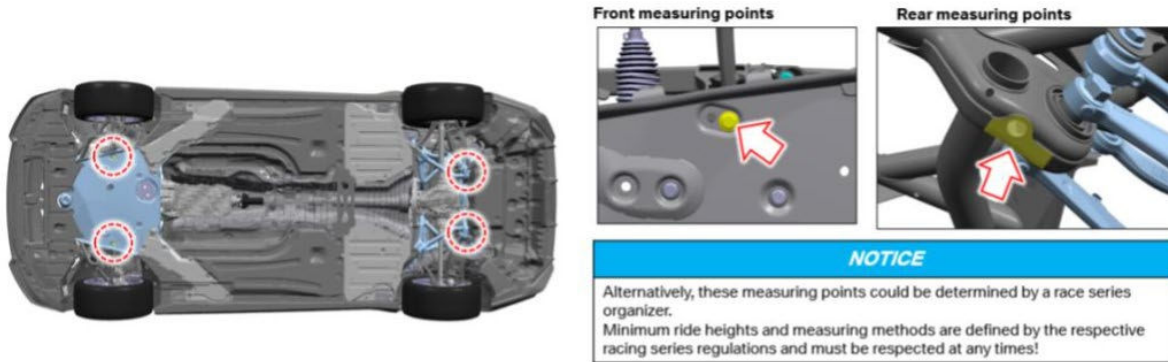

(Figures – Vehicle underbody and measurement points to determine ride height)

Ride height must always be at least 95 mm at the front axle and 133 mm at the rear axle during an event.

Inspection takes place at the event organiser’s designated reference area.

Tyre pressures may be increased to the reference pressure (2.0 bar) for the measurement procedure.

The tyres fitted at the time of the inspection are to be used for the ride height measurement.

If one or more tyres are unable to maintain the required pressure due to damage, the tyre(s) in question may be replaced.

2.18 Control units and software version

The control software and hardware may be inspected at any time by BMW and the Scrutineer/Chief Scrutineer and must always conform to the latest version of the Manual or the version defined by bulletin to the teams.

If this is not the case, it will be reported automatically to the Stewards at the event and to BMW.

BMW is entitled to update or replace the software version or the control hardware at any time. The entrant /driver (participant) is not permitted to overwrite or modify any data or program versions in the control units.

2.19 Air jack system

Air jack systems are optional.

If an air jack system is fitted, all parts listed in the EPC are to be installed in accordance with the instructions in the latest version of the G87 M2Racing Technical Customer Manual.